



Cisco uBR-3x10 RF Switch Hardware Installation and Cabling Guide

June 6, 2008

Americas Headquarters

Cisco Systems, Inc.
170 West Tasman Drive
San Jose, CA 95134-1706
USA
<http://www.cisco.com>
Tel: 408 526-4000
800 553-NETS (6387)
Fax: 408 527-0883

Text Part Number: OL-1984-06

THE SPECIFICATIONS AND INFORMATION REGARDING THE PRODUCTS IN THIS MANUAL ARE SUBJECT TO CHANGE WITHOUT NOTICE. ALL STATEMENTS, INFORMATION, AND RECOMMENDATIONS IN THIS MANUAL ARE BELIEVED TO BE ACCURATE BUT ARE PRESENTED WITHOUT WARRANTY OF ANY KIND, EXPRESS OR IMPLIED. USERS MUST TAKE FULL RESPONSIBILITY FOR THEIR APPLICATION OF ANY PRODUCTS.

THE SOFTWARE LICENSE AND LIMITED WARRANTY FOR THE ACCOMPANYING PRODUCT ARE SET FORTH IN THE INFORMATION PACKET THAT SHIPPED WITH THE PRODUCT AND ARE INCORPORATED HEREIN BY THIS REFERENCE. IF YOU ARE UNABLE TO LOCATE THE SOFTWARE LICENSE OR LIMITED WARRANTY, CONTACT YOUR CISCO REPRESENTATIVE FOR A COPY.

The following information is for FCC compliance of Class A devices: This equipment has been tested and found to comply with the limits for a Class A digital device, pursuant to part 15 of the FCC rules. These limits are designed to provide reasonable protection against harmful interference when the equipment is operated in a commercial environment. This equipment generates, uses, and can radiate radio-frequency energy and, if not installed and used in accordance with the instruction manual, may cause harmful interference to radio communications. Operation of this equipment in a residential area is likely to cause harmful interference, in which case users will be required to correct the interference at their own expense.

The following information is for FCC compliance of Class B devices: The equipment described in this manual generates and may radiate radio-frequency energy. If it is not installed in accordance with Cisco's installation instructions, it may cause interference with radio and television reception. This equipment has been tested and found to comply with the limits for a Class B digital device in accordance with the specifications in part 15 of the FCC rules. These specifications are designed to provide reasonable protection against such interference in a residential installation. However, there is no guarantee that interference will not occur in a particular installation.

Modifying the equipment without Cisco's written authorization may result in the equipment no longer complying with FCC requirements for Class A or Class B digital devices. In that event, your right to use the equipment may be limited by FCC regulations, and you may be required to correct any interference to radio or television communications at your own expense.

You can determine whether your equipment is causing interference by turning it off. If the interference stops, it was probably caused by the Cisco equipment or one of its peripheral devices. If the equipment causes interference to radio or television reception, try to correct the interference by using one or more of the following measures:

- Turn the television or radio antenna until the interference stops.
- Move the equipment to one side or the other of the television or radio.
- Move the equipment farther away from the television or radio.
- Plug the equipment into an outlet that is on a different circuit from the television or radio. (That is, make certain the equipment and the television or radio are on circuits controlled by different circuit breakers or fuses.)

Modifications to this product not authorized by Cisco Systems, Inc. could void the FCC approval and negate your authority to operate the product.

The Cisco implementation of TCP header compression is an adaptation of a program developed by the University of California, Berkeley (UCB) as part of UCB's public domain version of the UNIX operating system. All rights reserved. Copyright © 1981, Regents of the University of California.

NOTWITHSTANDING ANY OTHER WARRANTY HEREIN, ALL DOCUMENT FILES AND SOFTWARE OF THESE SUPPLIERS ARE PROVIDED "AS IS" WITH ALL FAULTS. CISCO AND THE ABOVE-NAMED SUPPLIERS DISCLAIM ALL WARRANTIES, EXPRESSED OR IMPLIED, INCLUDING, WITHOUT LIMITATION, THOSE OF MERCHANTABILITY, FITNESS FOR A PARTICULAR PURPOSE AND NONINFRINGEMENT OR ARISING FROM A COURSE OF DEALING, USAGE, OR TRADE PRACTICE.

IN NO EVENT SHALL CISCO OR ITS SUPPLIERS BE LIABLE FOR ANY INDIRECT, SPECIAL, CONSEQUENTIAL, OR INCIDENTAL DAMAGES, INCLUDING, WITHOUT LIMITATION, LOST PROFITS OR LOSS OR DAMAGE TO DATA ARISING OUT OF THE USE OR INABILITY TO USE THIS MANUAL, EVEN IF CISCO OR ITS SUPPLIERS HAVE BEEN ADVISED OF THE POSSIBILITY OF SUCH DAMAGES.

CCSP, the Cisco Square Bridge logo, Follow Me Browsing, and StackWise are trademarks of Cisco Systems, Inc.; Changing the Way We Work, Live, Play, and Learn, and iQuick Study are service marks of Cisco Systems, Inc.; and Access Registrar, Aironet, ASIST, BPX, Catalyst, CCDA, CCDP, CCIE, CCIP, CCNA, CCNP, Cisco, the Cisco Certified Internetwork Expert logo, Cisco IOS, Cisco Press, Cisco Systems, Cisco Systems Capital, the Cisco Systems logo, Cisco Unity, Empowering the Internet Generation, Enterprise/Solver, EtherChannel, EtherFast, EtherSwitch, Fast Step, FormShare, GigaDrive, GigaStack, HomeLink, Internet Quotient, IOS, IP/TV, iQ Expertise, the iQ logo, iQ Net Readiness Scorecard, LightStream, Linksys, MeetingPlace, MGX, the Networkers logo, Networking Academy, Network Registrar, Packet, PIX, Post-Routing, Pre-Routing, ProConnect, RateMUX, ScriptShare, SlideCast, SMARTnet, StrataView Plus, SwitchProbe, TeleRouter, The Fastest Way to Increase Your Internet Quotient, TransPath, and VCO are registered trademarks of Cisco Systems, Inc. and/or its affiliates in the United States and certain other countries.

All other trademarks mentioned in this document or Website are the property of their respective owners. The use of the word partner does not imply a partnership relationship between Cisco and any other company. (0501R)



Preface

This preface describes the objectives, intended audience, and organization of this document and explains how to find additional information on related products and services. This preface contains the following sections:

- [Document Objectives, page 3](#)
- [Audience, page 3](#)
- [Scope, page 4](#)
- [Document Organization, page 4](#)
- [Document Conventions, page 4](#)
- [Related Documentation, page 10](#)
- [Obtaining Documentation, page 11](#)
- [Documentation Feedback, page 12](#)
- [Obtaining Technical Assistance, page 12](#)
- [Obtaining Additional Publications and Information, page 13](#)

Document Objectives

Use this document as a guide when installing and cabling the Cisco uBR 3x10 RF Switch at the cable headend or distribution hub.

Audience

This guide is intended for cable system installers and technicians who physically install and connect the Cisco uBR 3x10 RF Switch and associated equipment at the cable headend or distribution hub. Cable system installers and technicians should be familiar with their cable plant's base operating parameters and service offerings.



Warning

Only trained and qualified personnel should be allowed to install, replace, or service this equipment.
Statement 1030

**Tip**

Statement numbers (Statement 1030) at the end of a warning refer to specific warnings and their translations found in the *Regulatory Compliance and Safety Information for the Cisco RF Switch*.

Scope

The guide provides installation and cabling information for the Cisco uBR 3x10 RF Switch. Refer to the “Related Documentation” section on page 10 for related Cisco publications that provide configuration information for the Cisco uBR 3x10 RF Switch.

Document Organization

This hardware installation guide is organized into the following chapters and appendixes:

Chapter Title	Description
Chapter 1, “Cisco uBR-3x10 RF Switch Overview”	Describes the Cisco uBR 3x10 RF Switch chassis and components, illustrating the supported system configurations.
Chapter 2, “Preparing for Installation”	Describes safety considerations, tools, and other equipment required to prepare your site.
Chapter 3, “Installing the Cisco RF Switch”	Provides instructions to install and connect cables to the chassis.
Chapter 4, “Cabling the RF Switch With the Cisco uBR10012 CMTS Cable Interface Line Cards”	Provides instructions for connecting Cisco uBR 3x10 RF Switch cable network redundancy cables in a Cisco uBR10012 CMTS environment.
Chapter 6, “Troubleshooting”	Provides basic Cisco uBR 3x10 RF Switch troubleshooting information.
Appendix A, “Specifications and Component Part Numbers”	Provides Cisco uBR 3x10 RF Switch system specifications.

Document Conventions

This guide uses the following conventions:

**Note**

Means *reader take note*. Notes contain helpful suggestions or references to materials not contained in this manual.

**Caution**

Means *reader be careful*. You are capable of doing something that might result in equipment damage or loss of data.



Tip

Means *the following information might help you solve a problem.*

Warning Definition



Warning

IMPORTANT SAFETY INSTRUCTIONS

This warning symbol means danger. You are in a situation that could cause bodily injury. Before you work on any equipment, be aware of the hazards involved with electrical circuitry and be familiar with standard practices for preventing accidents. Use the statement number provided at the end of each warning to locate its translation in the translated safety warnings that accompanied this device. Statement 1071

SAVE THESE INSTRUCTIONS

Waarschuwing

BELANGRIJKE VEILIGHEIDSINSTRUCTIES

Dit waarschuwingssymbool betekent gevaar. U verkeert in een situatie die lichamelijk letsel kan veroorzaken. Voordat u aan enige apparatuur gaat werken, dient u zich bewust te zijn van de bij elektrische schakelingen betrokken risico's en dient u op de hoogte te zijn van de standaard praktijken om ongelukken te voorkomen. Gebruik het nummer van de verklaring onderaan de waarschuwing als u een vertaling van de waarschuwing die bij het apparaat wordt geleverd, wilt raadplegen.

BEWAAR DEZE INSTRUCTIES

Varoitus

TÄRKEITÄ TURVALLISUUSOHJEITA

Tämä varoitusmerkki merkitsee vaaraa. Tilanne voi aiheuttaa ruumiillisia vammoja. Ennen kuin käsittelet laitteistoa, huomioi sähköpiirien käsittelemiseen liittyvät riskit ja tutustu onnettomuuksien yleisiin ehkäisytapoihin. Turvallisuusvaroitusten käännökset löytyvät laitteen mukana toimitettujen käännettyjen turvallisuusvaroitusten joukosta varoitusten lopussa näkyvien lausuntonumeroiden avulla.

SÄILYTÄ NÄMÄ OHJEET

Attention

IMPORTANTES INFORMATIONS DE SÉCURITÉ

Ce symbole d'avertissement indique un danger. Vous vous trouvez dans une situation pouvant entraîner des blessures ou des dommages corporels. Avant de travailler sur un équipement, soyez conscient des dangers liés aux circuits électriques et familiarisez-vous avec les procédures couramment utilisées pour éviter les accidents. Pour prendre connaissance des traductions des avertissements figurant dans les consignes de sécurité traduites qui accompagnent cet appareil, référez-vous au numéro de l'instruction situé à la fin de chaque avertissement.

CONSERVEZ CES INFORMATIONS

Warnung WICHTIGE SICHERHEITSHINWEISE

Dieses Warnsymbol bedeutet Gefahr. Sie befinden sich in einer Situation, die zu Verletzungen führen kann. Machen Sie sich vor der Arbeit mit Geräten mit den Gefahren elektrischer Schaltungen und den üblichen Verfahren zur Vorbeugung vor Unfällen vertraut. Suchen Sie mit der am Ende jeder Warnung angegebenen Anweisungsnummer nach der jeweiligen Übersetzung in den übersetzten Sicherheitshinweisen, die zusammen mit diesem Gerät ausgeliefert wurden.

BEWAHREN SIE DIESE HINWEISE GUT AUF.

Avvertenza IMPORTANTI ISTRUZIONI SULLA SICUREZZA

Questo simbolo di avvertenza indica un pericolo. La situazione potrebbe causare infortuni alle persone. Prima di intervenire su qualsiasi apparecchiatura, occorre essere al corrente dei pericoli relativi ai circuiti elettrici e conoscere le procedure standard per la prevenzione di incidenti. Utilizzare il numero di istruzione presente alla fine di ciascuna avvertenza per individuare le traduzioni delle avvertenze riportate in questo documento.

CONSERVARE QUESTE ISTRUZIONI

Advarsel VIKTIGE SIKKERHETSINSTRUKSJONER

Dette advarselssymbolet betyr fare. Du er i en situasjon som kan føre til skade på person. Før du begynner å arbeide med noe av utstyret, må du være oppmerksom på farene forbundet med elektriske kretser, og kjenne til standardprosedyrer for å forhindre ulykker. Bruk nummeret i slutten av hver advarsel for å finne oversettelsen i de oversatte sikkerhetsadvarslene som fulgte med denne enheten.

TA VARE PÅ DISSE INSTRUKSJONENE

Aviso INSTRUÇÕES IMPORTANTES DE SEGURANÇA

Este símbolo de aviso significa perigo. Você está em uma situação que poderá ser causadora de lesões corporais. Antes de iniciar a utilização de qualquer equipamento, tenha conhecimento dos perigos envolvidos no manuseio de circuitos elétricos e familiarize-se com as práticas habituais de prevenção de acidentes. Utilize o número da instrução fornecido ao final de cada aviso para localizar sua tradução nos avisos de segurança traduzidos que acompanham este dispositivo.

GUARDE ESTAS INSTRUÇÕES

¡Advertencia! INSTRUCCIONES IMPORTANTES DE SEGURIDAD

Este símbolo de aviso indica peligro. Existe riesgo para su integridad física. Antes de manipular cualquier equipo, considere los riesgos de la corriente eléctrica y familiarícese con los procedimientos estándar de prevención de accidentes. Al final de cada advertencia encontrará el número que le ayudará a encontrar el texto traducido en el apartado de traducciones que acompaña a este dispositivo.

GUARDE ESTAS INSTRUCCIONES

Varning! VIKTIGA SÄKERHETSANVISNINGAR

Denna varningssignal signalerar fara. Du befinner dig i en situation som kan leda till personskada. Innan du utför arbete på någon utrustning måste du vara medveten om farorna med elkretsar och känna till vanliga förfaranden för att förebygga olyckor. Använd det nummer som finns i slutet av varje varning för att hitta dess översättning i de översatta säkerhetsvarningar som medföljer denna anordning.

SPARA DESSA ANVISNINGAR**FONTOS BIZTONSÁGI ELOÍRÁSOK**

Ez a figyelmeztető jel veszélyre utal. Sérülésveszélyt rejtő helyzetben van. Mielőtt bármely berendezésen munkát végezte, legyen figyelemmel az elektromos áramkörök okozta kockázatokra, és ismerkedjen meg a szokásos balesetvédelmi eljárásokkal. A kiadványban szereplő figyelmeztetések fordítása a készülékhez mellékelt biztonsági figyelmeztetések között található; a fordítás az egyes figyelmeztetések végén látható szám alapján kereshető meg.

ORIZZE MEG EZEKET AZ UTASÍTÁSOKAT!**Предупреждение****ВАЖНЫЕ ИНСТРУКЦИИ ПО СОБЛЮДЕНИЮ ТЕХНИКИ БЕЗОПАСНОСТИ**

Этот символ предупреждения обозначает опасность. То есть имеет место ситуация, в которой следует опасаться телесных повреждений. Перед эксплуатацией оборудования выясните, каким опасностям может подвергаться пользователь при использовании электрических цепей, и ознакомьтесь с правилами техники безопасности для предотвращения возможных несчастных случаев. Воспользуйтесь номером заявления, приведенным в конце каждого предупреждения, чтобы найти его переведенный вариант в переводе предупреждений по безопасности, прилагаемом к данному устройству.

СОХРАНИТЕ ЭТИ ИНСТРУКЦИИ**警告 重要的安全性说明**

此警告符号代表危险。您正处于可能受到严重伤害的工作环境中。在您使用设备开始工作之前，必须充分意识到触电的危险，并熟练掌握防止事故发生的标准工作程序。请根据每项警告结尾提供的声明号码来找到此设备的安全性警告说明的翻译文本。

请保存这些安全性说明

警告 安全上の重要な注意事項

「危険」の意味です。人身事故を予防するための注意事項が記述されています。装置の取り扱い作業を行うときは、電気回路の危険性に注意し、一般的な事故防止策に留意してください。警告の各国語版は、各注意事項の番号を基に、装置に付属の「Translated Safety Warnings」を参照してください。

これらの注意事項を保管しておいてください。

주의 **중요 안전 지침**

이 경고 기호는 위험을 나타냅니다. 작업자가 신체 부상을 일으킬 수 있는 위험한 환경에 있습니다. 장비에 작업을 수행하기 전에 전기 회로와 관련된 위험을 숙지하고 표준 작업 관례를 숙지하여 사고를 방지하십시오. 각 경고의 마지막 부분에 있는 경고문 번호를 참조하여 이 장치와 함께 제공되는 번역된 안전 경고문에서 해당 번역문을 찾으십시오.

이 지시 사항을 보관하십시오.

Aviso **INSTRUÇÕES IMPORTANTES DE SEGURANÇA**

Este símbolo de aviso significa perigo. Você se encontra em uma situação em que há risco de lesões corporais. Antes de trabalhar com qualquer equipamento, esteja ciente dos riscos que envolvem os circuitos elétricos e familiarize-se com as práticas padrão de prevenção de acidentes. Use o número da declaração fornecido ao final de cada aviso para localizar sua tradução nos avisos de segurança traduzidos que acompanham o dispositivo.

GUARDE ESTAS INSTRUÇÕES**Advarsel** **VIGTIGE SIKKERHEDSANVISNINGER**

Dette advarselssymbol betyder fare. Du befinder dig i en situation med risiko for legemeskadedigelse. Før du begynder arbejde på udstyr, skal du være opmærksom på de involverede risici, der er ved elektriske kredsløb, og du skal sætte dig ind i standardprocedurer til undgåelse af ulykker. Brug erklæringsnummeret efter hver advarsel for at finde oversættelsen i de oversatte advarsler, der fulgte med denne enhed.

GEM DISSE ANVISNINGER**تحذير****إرشادات الأمان الهامة**

يوضح رمز التحذير هذا وجود خطر. وهذا يعني أنك متواجد في مكان قد ينتج عنه التعرض لإصابات. قبل بدء العمل، احذر مخاطر التعرض للصدمة الكهربائية وكن على علم بالإجراءات القياسية للحيلولة دون وقوع أي حوادث. استخدم رقم البيان الموجود في آخر كل تحذير لتحديد مكان ترجمته داخل تحذيرات الأمان المترجمة التي تأتي مع الجهاز. قم بحفظ هذه الإرشادات

Upozorenje **VAŽNE SIGURNOSNE NAPOMENE**

Ovaj simbol upozorenja predstavlja opasnost. Nalazite se u situaciji koja može prouzročiti tjelesne ozljede. Prije rada s bilo kojim uređajem, morate razumjeti opasnosti vezane uz električne sklopove, te biti upoznati sa standardnim načinima izbjegavanja nesreća. U prevedenim sigurnosnim upozorenjima, priloženima uz uređaj, možete prema broju koji se nalazi uz pojedino upozorenje pronaći i njegov prijevod.

SAČUVAJTE OVE UPUTE

Upozornění DŮLEŽITÉ BEZPEČNOSTNÍ POKYNY

Tento upozorňující symbol označuje nebezpečí. Jste v situaci, která by mohla způsobit nebezpečí úrazu. Před prací na jakémkoliv vybavení si uvědomte nebezpečí související s elektrickými obvody a seznamte se se standardními opatřeními pro předcházení úrazům. Podle čísla na konci každého upozornění vyhledejte jeho překlad v přeložených bezpečnostních upozorněních, která jsou přiložena k zařízení.

USCHOVEJTE TYTO POKYNY**Προειδοποίηση ΣΗΜΑΝΤΙΚΕΣ ΟΔΗΓΙΕΣ ΑΣΦΑΛΕΙΑΣ**

Αυτό το προειδοποιητικό σύμβολο σημαίνει κίνδυνο. Βρίσκεστε σε κατάσταση που μπορεί να προκαλέσει τραυματισμό. Πριν εργαστείτε σε οποιοδήποτε εξοπλισμό, να έχετε υπόψη σας τους κινδύνους που σχετίζονται με τα ηλεκτρικά κυκλώματα και να έχετε εξοικειωθεί με τις συνήθειες πρακτικές για την αποφυγή ατυχημάτων. Χρησιμοποιήστε τον αριθμό δήλωσης που παρέχεται στο τέλος κάθε προειδοποίησης, για να εντοπίσετε τη μετάφρασή της στις μεταφρασμένες προειδοποιήσεις ασφαλείας που συνοδεύουν τη συσκευή.

ΦΥΛΑΞΤΕ ΑΥΤΕΣ ΤΙΣ ΟΔΗΓΙΕΣ**אזהרה****הוראות בטיחות חשובות**

סימן אזהרה זה מסמל סכנה. אתה נמצא במצב העלול לגרום לפציעה. לפני שתעבוד עם ציוד כלשהו, עליך להיות מודע לסכנות הכרוכות במגלים חשמליים ולהכיר את הנהלים המקובלים למניעת תאונות. השתמש במספר ההוראה המסופק בסופה של כל אזהרה כדי לאתר את התרגום באזהרות הבטיחות המתורגמות שמצורפות להתקן.

שמור הוראות אלה**Opomena**

постои кај електричните кола и треба да ги познавате стандардните постапки за спречување на несреќни случаи. Искористете го бројот на изјавата што се наоѓа на крајот на секое предупредување за да го најдете неговиот период во преведените безбедносни предупредувања што се испорачани со уредот.
ЧУВАЈТЕ ГИ ОБИЕ НАПАТСТВИЈА

Ostrzeżenie WAŻNE INSTRUKCJE DOTYCZĄCE BEZPIECZEŃSTWA

Ten symbol ostrzeżenia oznacza niebezpieczeństwo. Zachodzi sytuacja, która może powodować obrażenia ciała. Przed przystąpieniem do prac przy urządzeniach należy zapoznać się z zagrożeniami związanymi z układami elektrycznymi oraz ze standardowymi środkami zapobiegania wypadkom. Na końcu każdego ostrzeżenia podano numer, na podstawie którego można odszukać tłumaczenie tego ostrzeżenia w dołączonym do urządzenia dokumencie z tłumaczeniami ostrzeżeń.

NINIEJSZE INSTRUKCJE NALEŻY ZACHOWAĆ

Upozornenie DÔLEŽITÉ BEZPEČNOSTNÉ POKYNY

Tento varovný symbol označuje nebezpečenstvo. Nachádzate sa v situácii s nebezpečenstvom úrazu. Pred prácou na akomkoľvek vybavení si uvedomte nebezpečenstvo súvisiace s elektrickými obvodmi a oboznámte sa so štandardnými opatreniami na predchádzanie úrazom. Podľa čísla na konci každého upozornenia vyhľadajte jeho preklad v preložených bezpečnostných upozorneniach, ktoré sú priložené k zariadeniu.

USCHOVAJTE SI TENTO NÁVOD

Related Documentation

For high availability (HA) information, see:

- *N+1 Redundancy Using the Cisco RF Switch* at the following URL:
http://www.cisco.com/en/US/partner/tech/tk86/tk804/technologies_tech_note09186a0080204374.shtml
- *N+1 Solution for the uBR10012* at the following url:
http://www.cisco.com/en/US/partner/products/hw/cable/ps2209/products_tech_note09186a00801f7638.shtml
- *N+1 Solution for the uBR7200 with MC28C or MC16x Cards* at the following URL:
http://www.cisco.com/en/US/customer/tech/tk86/tk804/technologies_tech_note09186a0080205618.shtml
- *N+1 Redundancy using the Vecima HD4040 Upconverter* at the following URL:
http://www.cisco.com/en/US/customer/tech/tk86/tk804/technologies_tech_note09186a00801f7622.shtml
- *N+1 Feature Updates (N+1/5x20 and N+1/CLI sync)* at the following URLs:
http://www.cisco.com/univercd/cc/td/doc/product/cable/cab_rout/cmtsfg/index.htm
http://www.cisco.com/en/US/products/hw/cable/ps2217/products_configuration_guide_chapter09186a008015096c.html
- “*N+1 Redundancy for the Cisco CMTS*” chapter of the *Cisco Cable Modem Termination System Feature Guide*, at the following URL:
http://www.cisco.com/en/US/products/hw/cable/ps2217/products_feature_guide09186a008015096c.html

For installation information, see:

- *Rack-Mounting the Cisco RF Switch with the Cisco uBR10012 CMTS*, at the following URL:
<http://www.cisco.com/univercd/cc/td/doc/product/cable/rfswitch/index.htm>
- *Rack-Mounting the Cisco RF Switch with the Cisco uBR7246VXR CMTS*, at the following URL:
<http://www.cisco.com/univercd/cc/td/doc/product/cable/rfswitch/index.htm>

- *Cabling the Cisco uBR 3x10 RF Switch*, at the following URL:
<http://www.cisco.com/univercd/cc/td/doc/product/cable/rfswitch/index.htm>
- Vecima HD4040 series IF-to-RF upconverter, at the following URL:
<http://www.vecima.com>

For other information, see:

- *Cisco uBR 3x10 Switch Documentation Roadmap*, at the following URL:
<http://www.cisco.com/univercd/cc/td/doc/product/cable/rfswitch/rdmp310.htm>
- *Regulatory Compliance and Safety Information for the Cisco RF Switch*, at the following URL:
http://www.cisco.com/univercd/cc/td/doc/product/cable/rfswitch/rfs_rcsi.htm
- Warranty information, at the following URL:
http://www.cisco.com/univercd/cc/td/doc/es_inpck/cetrans.htm

Obtaining Documentation

Cisco documentation and additional literature are available on Cisco.com. Cisco also provides several ways to obtain technical assistance and other technical resources. These sections explain how to obtain technical information from Cisco Systems.

Cisco.com

You can access the most current Cisco documentation at this URL:

<http://www.cisco.com/univercd/home/home.htm>

You can access the Cisco website at this URL:

<http://www.cisco.com>

You can access international Cisco websites at this URL:

http://www.cisco.com/public/countries_languages.shtml

Ordering Documentation

You can find instructions for ordering documentation at this URL:

http://www.cisco.com/univercd/cc/td/doc/es_inpck/pdi.htm

You can order Cisco documentation in these ways:

- Registered Cisco.com users (Cisco direct customers) can order Cisco product documentation from the Ordering tool:
<http://www.cisco.com/en/US/partner/ordering/index.shtml>
- Nonregistered Cisco.com users can order documentation through a local account representative by calling Cisco Systems Corporate Headquarters (California, USA) at 408 526-7208 or, elsewhere in North America, by calling 800 553-NETS (6387).

Documentation Feedback

You can send comments about technical documentation to bug-doc@cisco.com.

You can submit comments by using the response card (if present) behind the front cover of your document or by writing to the following address:

Cisco Systems
Attn: Customer Document Ordering
170 West Tasman Drive
San Jose, CA 95134-9883

We appreciate your comments.

Obtaining Technical Assistance

For all customers, partners, resellers, and distributors who hold valid Cisco service contracts, Cisco Technical Support provides 24-hour-a-day, award-winning technical assistance. The Cisco Technical Support Website on Cisco.com features extensive online support resources. In addition, Cisco Technical Assistance Center (TAC) engineers provide telephone support. If you do not hold a valid Cisco service contract, contact your reseller.

Cisco Technical Support Website

The Cisco Technical Support Website provides online documents and tools for troubleshooting and resolving technical issues with Cisco products and technologies. The website is available 24 hours a day, 365 days a year at this URL:

<http://www.cisco.com/techsupport>

Access to all tools on the Cisco Technical Support Website requires a Cisco.com user ID and password. If you have a valid service contract but do not have a user ID or password, you can register at this URL:

<http://tools.cisco.com/RPF/register/register.do>

Submitting a Service Request

Using the online TAC Service Request Tool is the fastest way to open S3 and S4 service requests. (S3 and S4 service requests are those in which your network is minimally impaired or for which you require product information.) After you describe your situation, the TAC Service Request Tool automatically provides recommended solutions. If your issue is not resolved using the recommended resources, your service request will be assigned to a Cisco TAC engineer. The TAC Service Request Tool is located at this URL:

<http://www.cisco.com/techsupport/servicerequest>

For S1 or S2 service requests or if you do not have Internet access, contact the Cisco TAC by telephone. (S1 or S2 service requests are those in which your production network is down or severely degraded.) Cisco TAC engineers are assigned immediately to S1 and S2 service requests to help keep your business operations running smoothly.

To open a service request by telephone, use one of the following numbers:

Asia-Pacific: +61 2 8446 7411 (Australia: 1 800 805 227)

EMEA: +32 2 704 55 55

USA: 1 800 553 2447

For a complete list of Cisco TAC contacts, go to this URL:

<http://www.cisco.com/techsupport/contacts>

Definitions of Service Request Severity

To ensure that all service requests are reported in a standard format, Cisco has established severity definitions.

Severity 1 (S1)—Your network is “down,” or there is a critical impact to your business operations. You and Cisco will commit all necessary resources around the clock to resolve the situation.

Severity 2 (S2)—Operation of an existing network is severely degraded, or significant aspects of your business operation are negatively affected by inadequate performance of Cisco products. You and Cisco will commit full-time resources during normal business hours to resolve the situation.

Severity 3 (S3)—Operational performance of your network is impaired, but most business operations remain functional. You and Cisco will commit resources during normal business hours to restore service to satisfactory levels.

Severity 4 (S4)—You require information or assistance with Cisco product capabilities, installation, or configuration. There is little or no effect on your business operations.

Obtaining Additional Publications and Information

Information about Cisco products, technologies, and network solutions is available from various online and printed sources.

- Cisco Marketplace provides a variety of Cisco books, reference guides, and logo merchandise. Visit Cisco Marketplace, the company store, at this URL:

<http://www.cisco.com/go/marketplace/>

- The Cisco *Product Catalog* describes the networking products offered by Cisco Systems, as well as ordering and customer support services. Access the Cisco Product Catalog at this URL:

<http://cisco.com/univercd/cc/td/doc/pcat/>

- *Cisco Press* publishes a wide range of general networking, training and certification titles. Both new and experienced users will benefit from these publications. For current Cisco Press titles and other information, go to Cisco Press at this URL:

<http://www.ciscopress.com>

- *Packet* magazine is the Cisco Systems technical user magazine for maximizing Internet and networking investments. Each quarter, Packet delivers coverage of the latest industry trends, technology breakthroughs, and Cisco products and solutions, as well as network deployment and troubleshooting tips, configuration examples, customer case studies, certification and training information, and links to scores of in-depth online resources. You can access Packet magazine at this URL:

<http://www.cisco.com/packet>

- *iQ Magazine* is the quarterly publication from Cisco Systems designed to help growing companies learn how they can use technology to increase revenue, streamline their business, and expand services. The publication identifies the challenges facing these companies and the technologies to help solve them, using real-world case studies and business strategies to help readers make sound technology investment decisions. You can access iQ Magazine at this URL:

<http://www.cisco.com/go/iqmagazine>

- *Internet Protocol Journal* is a quarterly journal published by Cisco Systems for engineering professionals involved in designing, developing, and operating public and private internets and intranets. You can access the Internet Protocol Journal at this URL:

<http://www.cisco.com/ipj>

- World-class networking training is available from Cisco. You can view current offerings at this URL:

<http://www.cisco.com/en/US/learning/index.html>



CHAPTER 1

Cisco uBR-3x10 RF Switch Overview

This chapter describes the Cisco uBR 3x10 RF Switch. The chapter contains the following sections:

- [About the Cisco uBR 3x10 RF Switch, page 1-1](#)
- [Hardware Component Descriptions, page 1-4](#)
- [Cable Kits, page 1-10](#)

About the Cisco uBR 3x10 RF Switch

The Cisco uBR 3x10 RF Switch is designed to work with the Cisco uBR10012 CMTS or the Cisco uBR7246VXR CMTS in a cable headend or hub to provide N+1 redundancy for applications such as Voice over IP (VoIP).

The Cisco uBR 3x10 RF Switch is a rack-mount unit that contains the RF combiners and splitters, RF switches, and switch drivers. The RF switch uses Cisco RF Switch logic, and a Simple Network Management Protocol (SNMP) control interface. The Cisco uBR 3x10 RF Switch can be controlled using SNMP from the Cisco uBR10012 CMTS or the Cisco uBR7246VXR CMTS.

Chassis Features

The Cisco uBR 3x10 RF Switch chassis features:

- One power-supply module that provides either 100 to 240 VAC or –48 to –60 VDC power to the Cisco uBR 3x10 RF Switch chassis.
- One Ethernet controller module that provides SNMP control for automatic redundancy channel selection.
- Ten upstream (low-frequency) switch modules that provide 75-ohm termination and automatic upstream redundancy switching from 5 to 70 MHz.
- Three downstream (high-frequency) switch modules that provide 75-ohm termination and automatic downstream redundancy switching from 54 to 860 MHz.
- Eight power divider assemblies used to route signals to and from the appropriate upstream or downstream assemblies or protect interfaces.
- One midplane assembly that distributes power and control signals from the power supply and Ethernet controller to the upstream and downstream switch assemblies.

Other chassis features include:

- Front panel serviceability—for no downtime on RF interfaces. All active modules can be replaced from the front panel.
- 10BASE-T Ethernet interface over which you can control the configuration and operation of the Cisco uBR 3x10 RF Switch by means of SNMP from a Cisco universal broadband router.
- Upstream and downstream assembly online insertion and removal (OIR) or “hot swapping” capability.
- CLEI codes for all replaceable modules.
- Rack-mountable—Each unit can be rack-mounted into any rack or cabinet that is designed per EIA-310 or MIL-STD-189 using the supplied rack-mount brackets.

The Ethernet controller, power supply, upstream modules, and downstream modules are accessed from the front of the chassis. (See [Figure 1-1](#).)

Figure 1-1 Front View of the Cisco uBR-3x10 RF Switch

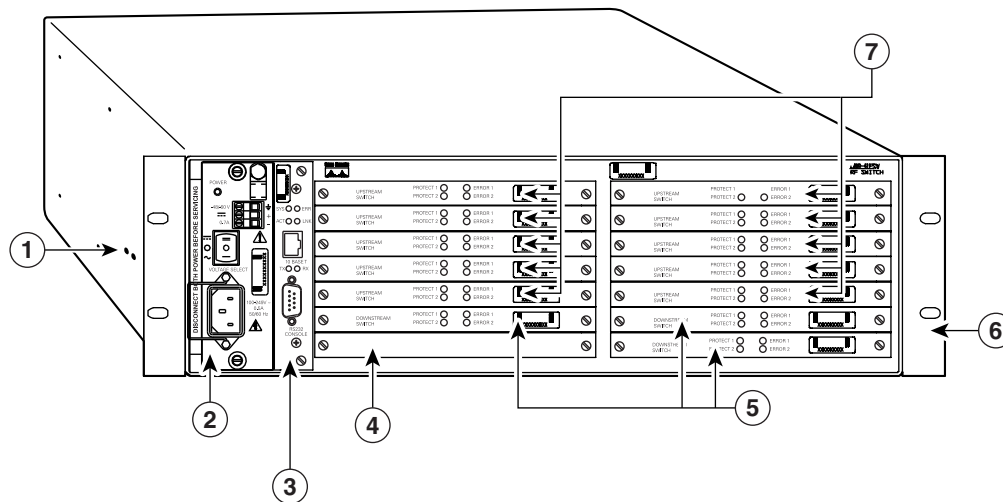

103285

1	Ground lug installation location	5	Downstream switch modules (3)
2	Power supply	6	Mounting brackets
3	Ethernet controller module	7	Upstream switch modules (10)
4	Blank slot		



Note

[Figure 1-1](#) shows the mounting brackets located at the front of the chassis. The brackets can also be mounted at the rear of the chassis.

The CMTS, PROTECT, and CABLE PLANT MCX connections are accessed from the rear of the RF switch chassis. (see [Figure 1-2](#).)

Figure 1-2 Rear View of the Cisco uBR-3x10 RF Switch

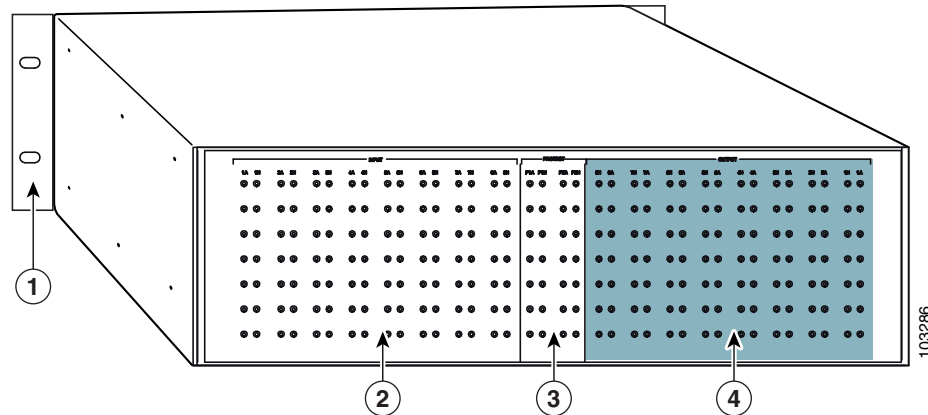

1	Mounting brackets	3	PROTECT MCX connector location
2	CMTS (working) MCX connector location	4	CABLE PLANT MCX connector location

Interface Overview

The following sections describe interface numbering, and MAC address assignments.

Interface Numbering

In all of the Cisco RF switches, the slot number is the chassis slot in which an Ethernet controller or an upstream switch module or downstream switch module is installed, and the logical interface number is the physical location of the interface port on an Ethernet controller.

The MAC-layer or hardware address is a standardized data link layer address that is required for certain network interface types. The Cisco uBR 3x10 RF Switch uses a specific method to assign and control the MAC-layer addresses of its Ethernet controller.

The Ethernet controller and upstream and downstream module slots keep the same slot number regardless of whether other Ethernet controllers or upstream or downstream modules are installed or removed. However, when you move an upstream or downstream module to a different slot, the logical interface number changes to reflect the new slot number. The Ethernet card is always installed in the same slot.

For complete descriptions and instructions for the commands used to configure your Cisco RF switch, refer to the “N+1 Redundancy for the Cisco CMTS” chapter of the *Cisco CMTS Feature Guide*, which is available on Cisco.com. (See the [“Obtaining Documentation”](#) section on page 11.)

MAC-Layer Address Assignments

All LAN interfaces (ports) require unique MAC-layer addresses, also known as hardware addresses. Typically, the MAC address of an interface is stored on a memory component that resides directly on the interface circuitry; however, the online insertion and removal (OIR) feature requires a different method.

OIR Feature

The OIR feature allows you to remove an Ethernet controller or an upstream or downstream module and replace it with another identically configured one. If the new controller or module matches the controller or module you removed, the system immediately brings it online. To allow OIR, an address allocator with a unique MAC address is stored in an EEPROM on the Cisco RF switch midplane. Each address is reserved for a specific port and slot in the switch, regardless of whether an Ethernet controller or an upstream or downstream switch module resides in that slot.

Slot MAC Addresses

The MAC addresses are assigned to the slots in sequence. The first address is assigned to Ethernet controller slot 0, and the next addresses are assigned to upstream and downstream card slots 1 through 14 (refer to the “Cisco uBR 3x10 RF Switch Slot Information” section on page 6-7 for slot location information). This address scheme allows you to remove the Ethernet controllers or upstream and downstream cards and insert them into other switches without causing the MAC addresses to move around the network or be assigned to multiple devices.

Hardware Component Descriptions

The following components are included in the Cisco uBR 3x10 RF Switch chassis:

- Power supply module
- Ethernet controller module
- Upstream (low-frequency) switch modules
- Downstream (high-frequency) switch modules

Power Supply Module

- Cisco part number 74-2624-01 (see [Figure 1-3 on page 1-5](#)).

The power supply module takes 100 to 240 VAC input and provides +12 VDC output. It also takes -40.5 to -72 VDC input and supplies +12 VDC output.

A control switch on the front panel is used to select DC input or AC input operation. This a 20-W power supply.

**Caution**

When inserting or removing the power supply from the Cisco uBR 3x10 RF Switch chassis, you must use a screwdriver to tighten and loosen the captive installation screws.

Figure 1-3 Power Supply Module

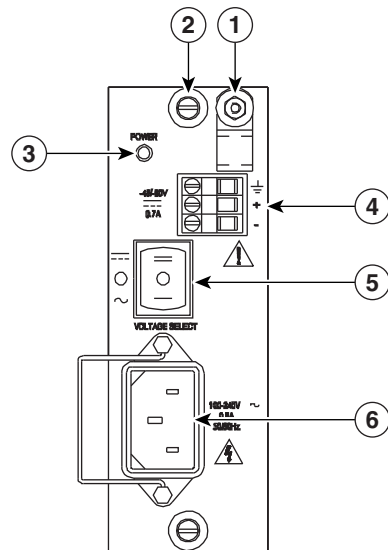

1	Strain relief for DC power cables	5	Power select switch (power off, AC, or DC). This is a three way toggle switch, the center position is off; toggle down for AC, toggle up for DC.
2	Captive screws		
3	Power LED (green-on)		
4	DC power connection	6	AC power input with strain relief retainer clip

Ethernet Controller Module

- Cisco part number 74-2620-01 (see [Figure 1-4 on page 1-6](#)).

Within the Cisco uBR 3x10 RF Switch system, only one Ethernet controller is used.

The Ethernet controller module performs two primary functions.

- Connecting the Cisco uBR 3x10 RF Switch to a Cisco uBR10012 router or a Cisco uBR7246VXR router. You can use a crossover cable to connect the Cisco CMTS to the RF switch Ethernet controller's RJ-45 receptacle. Or, you can use a straight-through cable to connect the RF switch and the CMTS through an ethernet switch or a hub. This connection allows you to remotely control both automatic and manual operations of the Cisco RF switch by passing SNMP traffic between the Cisco RF switch and the Cisco CMTS.

For example, when a cable interface line card on the Cisco universal broadband router experiences a failure or if the Cisco universal broadband router detects a large number of remote customer premises equipment (CPE) devices that have gone offline, an SNMP alert is automatically transmitted to the Cisco uBR 3x10 RF Switch and a protecting cable interface line card assumes working status for the failed or faulty cable interface line card.

- Connecting a console terminal to the Cisco uBR 3x10 RF Switch. You can use a rollover cable to connect the console terminal to the RF switch Ethernet controller's EIA/TIA-232 receptacle. This connection allows you to configure the Cisco uBR 3x10 RF Switch for N+1 redundancy. Use the configuration commands described in the "N+1 Redundancy for the Cisco CMTS" chapter of the *Cisco CMTS Feature Guide*, available on Cisco.com. (See the ["Obtaining Documentation" section on page 11](#).)

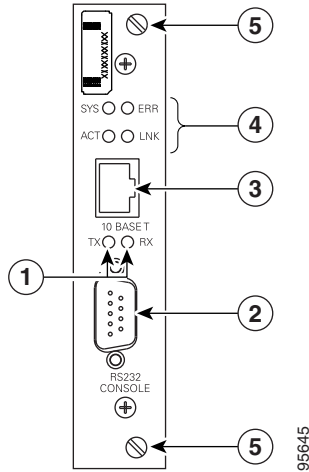
Figure 1-4 Ethernet Controller PCB Module

1	Transmit (TX) and receive (RX) LEDs	4	Status LEDs (SYS, ERR, ACT, LNK)
2	EAI/TIA-232 connection	5	Captive screws
3	RJ-45 connection		

Table 1-1 describes the Ethernet controller's LEDs.

Table 1-1 Ethernet Controller LEDs

LED	Function
SYS	Indicates that the Ethernet controller is enabled for operation in the system. This LED flashes while the RF switch is booting, and remains on during normal operation.
ERR	Indicates that a serious error has occurred either while booting the RF switch, or during line card operation.
ACT	Indicates that there is activity over the 10BASE-T Ethernet RJ-45 interface. This LED flashes as transmit/receive activity occurs.
LNK	Indicates that the Ethernet port has established a valid link with the network.
TX	This LED flashes as the Ethernet controller transmits data via the EIA/TIA-232 console port.
RX	This LED flashes as the Ethernet controller receives data via the EIA/TIA-232 console port.

Upstream Switch Modules

- Cisco part number 74-2622-01 (See [Figure 1-5](#).)

There are 10 upstream switch modules used in the Cisco uBR 3x10 RF Switch. The module operates over the from 5 to 70 MHz. Each module has ten 75-ohm inputs accessed through the MCX connectors on the backpanel of the RF switch (see [Figure 1-2 on page 1-3](#)). During normal system operation, all of the upstream switches direct traffic to their respective default termination interfaces.



Note

Upstream cables from the cable interface line cards are plugged into the CMTS MCX connections in the rear of the Cisco uBR 3x10 RF Switch. See [Chapter 4, “Cabling the RF Switch With the Cisco uBR10012 CMTS Cable Interface Line Cards,”](#) for more information about cabling the RF switch.

The upstream switch module takes the signal inputs (eight) from the power splitter and routes one of the eight to a protect output, or splits the inputs into two groups of four and sets up the switches to select one input (of a group of four) as a protect output. The relays are electromechanical, latching relays that are controlled through an I²C interface. The switch card provides a minimum of 60 dB of isolation from connector port to connector port during normal operation and more than 20 dB when operating in protect mode.

Figure 1-5 Upstream Switch Card

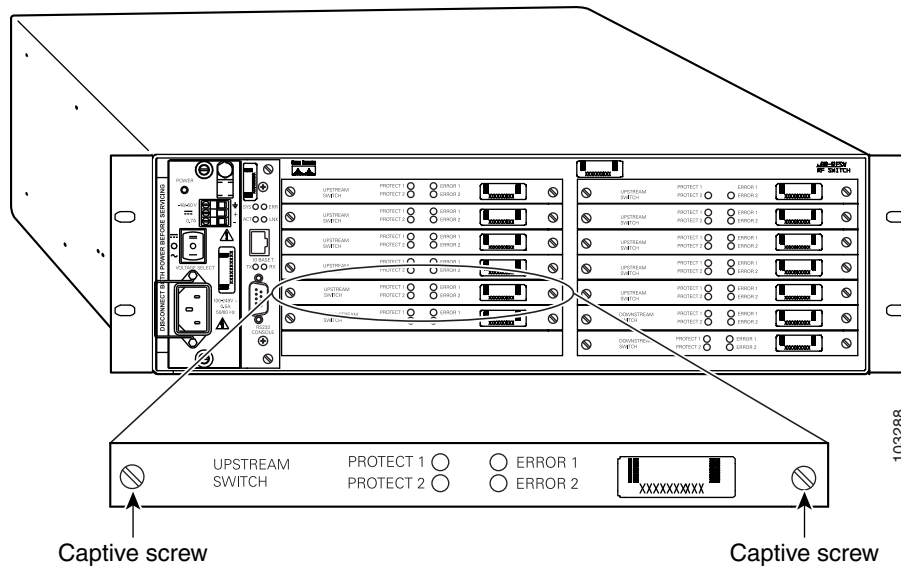

Each upstream switch has a set of four LEDs that indicate the working status of the port as described in [Table 1-2](#).

Table 1-2 Upstream Switch Board LED Descriptions

LED Name	Color	Description
Protect 1	Green/Yellow	Indicates CMTS/PROTECT 1
Protect 2	Green/ Yellow	Indicates CABLE PLANT/PROTECT 2
Error 1	Off/Yellow	Indicates a channel problem 1
Error 2	Off/Yellow	Indicates a channel problem 2

Downstream Switch Module

- Cisco part number 74-2623-01 (See [Figure 1-6 on page 1-8](#))

Three downstream (high-frequency) switch modules are used in the Cisco uBR 3x10 RF Switch. The module operates from 54 to 860 MHz. Each downstream switch module has ten 75-ohm inputs accessed through the CABLE PLANT MCX connectors on the backpanel of the RF switch. During normal system operation, the downstream switch module switches all direct traffic to their respective default termination interfaces.



Note

See [Chapter 4, “Cabling the RF Switch With the Cisco uBR10012 CMTS Cable Interface Line Cards,”](#) for more cabling information.

The downstream switch module accepts signal inputs (eight) from the power combiner and combines one of the eight to a protect output. Alternately, the switch splits the inputs into two groups of four and then selects one input (in the group of four) to combine with the protect input. The relays are electromechanical, latching relays that are controlled through an I²C interface. The switch card provides a minimum of 60 dB of isolation from connector port to connector port.

Figure 1-6 Downstream Switch PCB Assembly

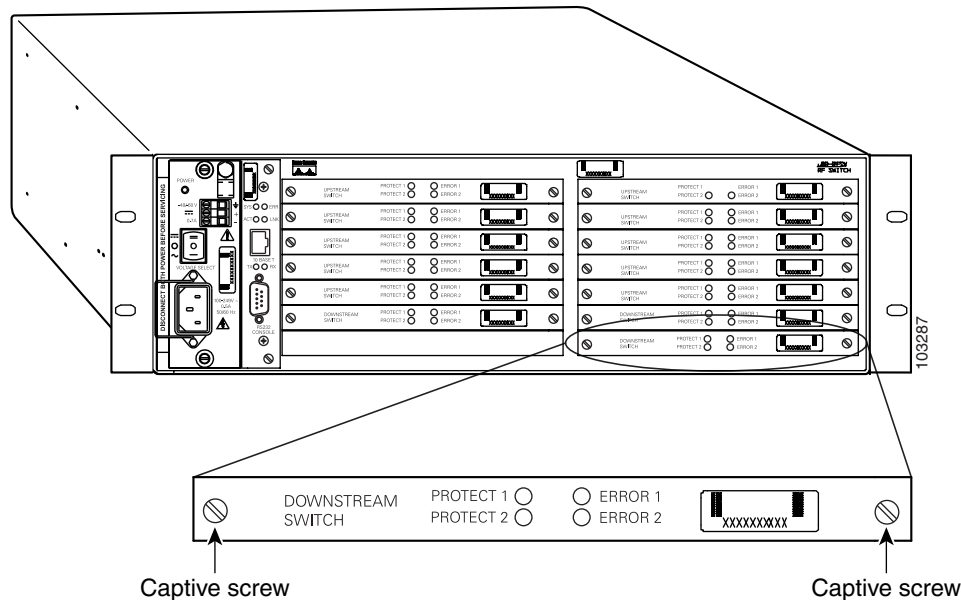

Each downstream switch board contains a set of four LEDs that indicates the working status of the port as described in [Table 1-3 on page 1-8](#).

Table 1-3 Downstream Switch Board LED Descriptions

LED Name	Color	Description
Protect 1	Green/Yellow	Indicates CMTS/PROTECT 1
Protect 2	Green/ Yellow	Indicates CABLE PLANT/PROTECT 2
Error 1	Off/Yellow	Indicates a channel problem 1
Error 2	Off/Yellow	Indicates a channel problem 2

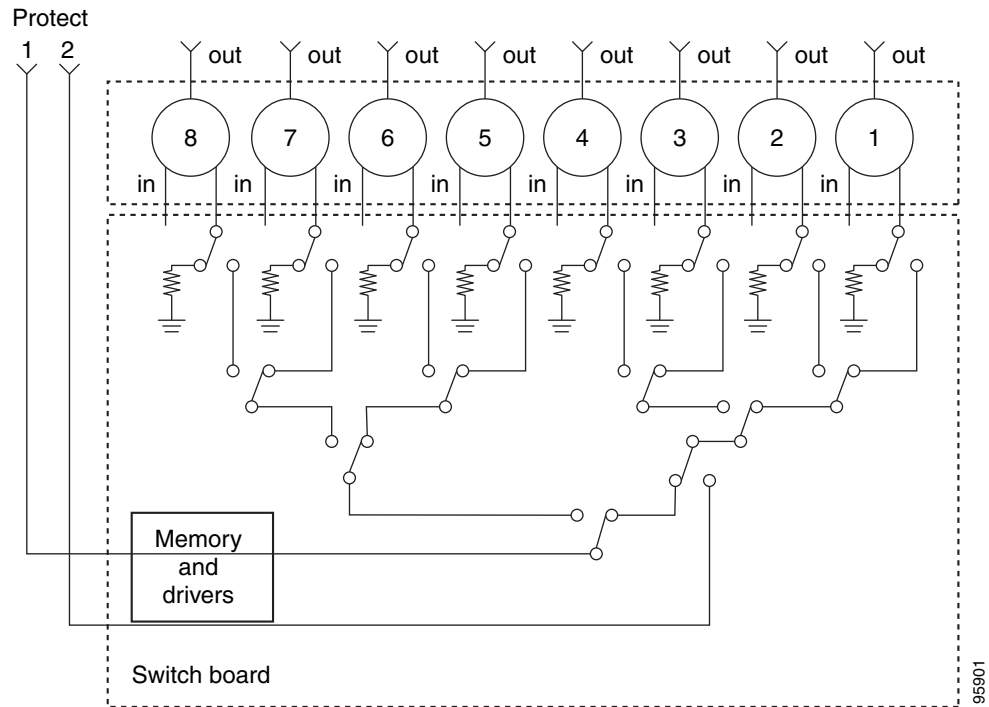
Figure 1-7 RF Switch Module Schematic (Upstream and Downstream)

Power Divider Assembly

The power divider assembly contains 16 splitters that operate from 5 to 860 MHz. The board also contains four protect feed-through connections. The power splitter provides a minimum of 60 dB of isolation from connector port to connector port.

The power divider assemblies are connected directly to the upstream and downstream card assemblies through an access area in the midplane card.



Note

This assembly is not a field-replaceable unit (FRU).

Midplane Assembly

The midplane assembly is located in the center of the chassis and connects the upstream and downstream to the power supply and Ethernet card assemblies. This card distributes +12V power, ground, and the I²C control signals to the 14 switch card positions available.



Note

This assembly is not a field-replaceable unit (FRU).

Cable Kits

The cables approved for use in the Cisco N+1 redundancy solution, are Mini Precision RG59 (95 percent) tinned copper braid with (100 percent) foil shield. This cable is serial digital interface (SDI) rated with a 1 MHz to 3 GHz rating.

- CAB-RFSW-3x10-T (bundled cable kit: 1.2-m, CMTS to RFS, F to MCX). This kit includes 10 cables, 2 cables have F-connectors on both ends for UPx connections and 2 are single 0.2-m cables, the others are 1.2-m F-connector to MCX-connector cables.
- CAB-RFSW-3x10-10T (bundled cable kit: 10-m, RFS to HUB, MCX to F). This kit includes 10 cables, 2 single 10-m cables, and 13 extra F-connectors.
- CAB-RFSW5X20TPMF (bundled cable kit, 3-m, MCX to F). This kit includes 2 bundles of 10 cables, 1 bundle of 5 cables, and 25 extra F-connectors.
- CAB-RFS5X20TIMM (bundled cable kit, 1-m, MCX to MCX). This kit includes 2 bundles of 10 cables, 1 bundle of 5 cables, and 4 headers (2 extra to be used with the output cable kit, CAB-RFSW-3x10-10T).

The different jacket colors are used for easy identification. The gray and brown RF cables are preterminated with the F-connectors used to connect to the Vecima HD4040 series IF-to-RF upconverter input.



CHAPTER 2

Preparing for Installation

This chapter describes the site requirements for installing the Cisco uBR 3x10 RF Switch. The chapter contains the following sections:

- [Safety, page 2-2](#)
- [Site Requirements, page 2-5](#)
- [Provisioning the Headend, page 2-7](#)
- [Tools for Installation, page 2-9](#)
- [Verifying the Shipping Container Contents, page 2-11](#)



Warning

Only trained and qualified personnel should be allowed to install, replace, or service this equipment.
Statement 1030



Warning

This unit is intended for installation in restricted access areas. A restricted access area can be accessed only through the use of a special tool, lock and key, or other means of security.
Statement 1017



Warning

This equipment must be installed and maintained by service personnel as defined by AS/NZS 3260. Incorrectly connecting this equipment to a general-purpose outlet could be hazardous. The telecommunications lines must be disconnected 1) before unplugging the main power connector or 2) while the housing is open, or both. Statement 1043



Warning

Ultimate disposal of this product should be handled according to all national laws and regulations.
Statement 1040

Safety

The following guidelines will help to ensure your safety and protect the equipment. This list does not cover all potentially hazardous situations, so *be alert*.

- The installation of your Cisco uBR 3x10 RF Switch should be in compliance with national and local electrical codes. In the United States, National Fire Protection Association (NFPA) 70, United States National Electrical Code. In Canada, Canadian Electrical Code, part I, CC22.1. In other countries, International Electrotechnical Commission (IEC) 364, part 1 through part 7.
- Review the safety warnings listed in the *Cisco RF Switch Regulatory Compliance and Safety Information* document before installing, configuring, or maintaining the Cisco uBR 3x10 RF Switch.
- Never attempt to lift an object that might be too heavy for you to lift by yourself.
- Always turn the power switch to the OFF (O) position and unplug the power cable before opening the chassis.
- Always unplug the power cable before installing or removing a chassis.
- Keep the chassis area clear and dust free during and after installation.
- Keep tools and chassis components away from walk areas.
- Do not wear loose clothing, jewelry (including rings and chains), or other items that could get caught in the chassis.
- The Cisco uBR 3x10 RF Switch operates safely when it is used in accordance with its marked electrical ratings and product usage instructions.

Lifting Safely

A fully configured Cisco uBR 3x10 RF Switch weighs approximately 36.6 lb (16.6 kg). This chassis is not intended to be moved frequently. Before you install the Cisco uBR 3x10 RF Switch, ensure that your site is properly prepared so that you can avoid having to move a chassis later to accommodate power sources and network connections.

Whenever you lift a chassis or any heavy object, follow these guidelines (see [Figure 2-1](#)):

- Always disconnect all external cables before lifting or moving the chassis.
- Do not attempt to lift the chassis by yourself; have someone assist you.
- Ensure that your footing is solid, and balance the weight of the object between your feet.
- Lift the chassis slowly; never move suddenly or twist your body as you lift.
- Keep your back straight and lift with your legs, not your back. If you must bend down to lift the chassis, bend at the knees, not at the waist, to reduce the strain on your lower back muscles.
- Lift the chassis from the bottom; grasp the underside of the chassis exterior with both hands.

Figure 2-1 Lifting the Chassis

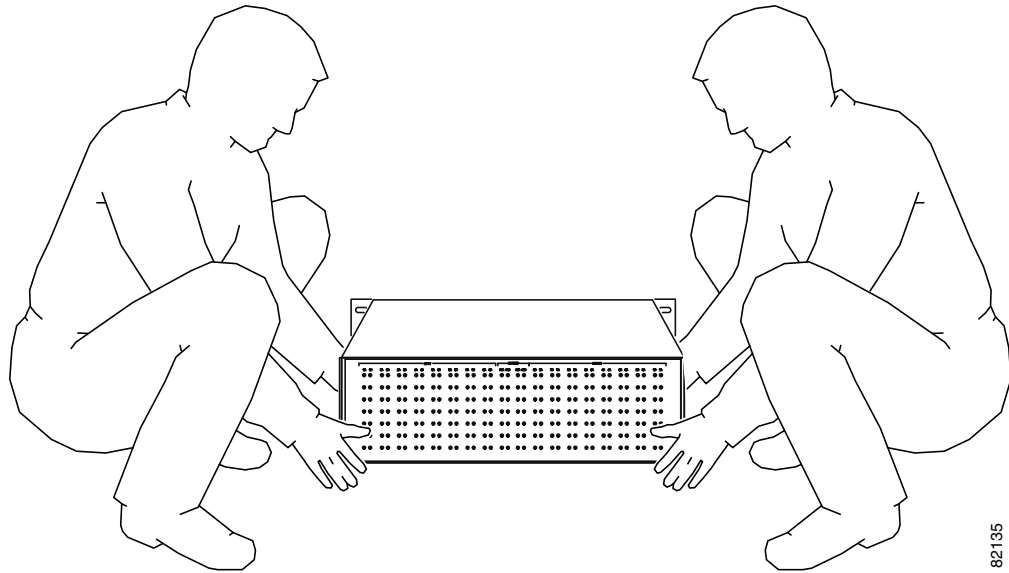

Safety with Electricity

The Ethernet controller and upstream and downstream switch modules are designed to be removed and replaced while the system is operating without presenting an electrical hazard or damage to the system.



Caution

You *must* power down the system before removing or replacing the power supply assembly.

Follow these basic guidelines when working with any electrical equipment:

- Before beginning any procedures requiring access to the chassis interior, locate the emergency power-off switch for the room in which you are working.
- Disconnect all power and external cables before installing or removing a chassis.
- Do not work alone if potentially hazardous conditions exist.
- Never assume that power has been disconnected from a circuit; always check.
- Do not perform any action that creates a potential hazard to people or makes the equipment unsafe.
- Never install equipment that appears damaged.
- Carefully examine your work area for possible hazards such as moist floors, ungrounded power extension cables, and missing safety grounds.



Warning

Before working on a chassis or working near power supplies, unplug the power cord on AC units; disconnect the power at the circuit breaker on DC units. Statement 12.

In addition, use the guidelines that follow when working with any equipment that is disconnected from a power source, but still connected to telephone wiring or other network cabling:

- Never install telephone wiring during a lightning storm.

- Never install telephone jacks in wet locations unless the jack is specifically designed for wet locations.
- Never touch uninsulated telephone wires or terminals unless the telephone line has been disconnected at the network interface.
- Use caution when installing or modifying telephone lines.

**Warning**

Do not work on the system or connect or disconnect cables during periods of lightning activity.
Statement 1001

Preventing Electrostatic Discharge Damage

Electrostatic discharge (ESD) damage, which occurs when electronic cards or components are improperly handled, can result in complete or intermittent system failures. The Ethernet controller, power supply, and each upstream and downstream assembly consists of a printed circuit board that is fixed in a metal carrier. Electromagnetic interference (EMI) shielding, connectors, and a handle are integral components of the carrier. Although the carrier helps protect the boards, use an antistatic strap whenever handling these assemblies. Handle the carriers by the handles and the carrier edges only; never touch the boards or connector pins.

**Caution**

Always tighten the captive installation screws on the Ethernet controller, power supply, and each upstream and downstream assembly. These screws prevent accidental removal, provide proper grounding for the system, and help ensure that the bus connectors are properly seated in the midplane.

Following are guidelines for preventing ESD damage:

- Always use an ESD wrist strap or ankle strap and ensure that it makes good skin contact.
- When handling Ethernet controllers, power supplies, and upstream and downstream assemblies that have been removed from the Cisco uBR 3x10 RF Switch chassis, make sure that the equipment end of your ESD strap is attached to an unfinished chassis surface of the router; *do not* touch the printed circuit board, and avoid contact between the printed circuit board and your clothing. Always place the Ethernet controller, power supply, and upstream or downstream assemblies component side up on an antistatic surface or in a static shielding bag. If you are returning the item to the factory, immediately place it in a static shielding bag.
- Ensure that the Ethernet assembly is fully inserted in its respective chassis slot and its captive installation screws are tightened. The captive installation screws prevent accidental removal, provide proper grounding for the system, and help ensure that the bus connectors are seated in the midplane.
- Ensure that each downstream and upstream switch assembly is fully inserted in its chassis slot and that its captive installation screws are tightened.
- Ensure that the power supply assembly is fully inserted in its chassis slot and that its captive installation screws are tightened.

**Caution**

For safety, periodically check the resistance value of the antistatic strap. The measurement should be between 1 and 10 megohms (Mohms).

Site Requirements

To ensure normal operation and avoid unnecessary maintenance, plan your site configuration and prepare your site *before* installation. Take into account the following criteria:

**Note**

To locate the most reliable channels for your downstream and upstream channel plans, we recommend that you perform a sweep of all available channels for at least a 24 hours to verify the presence or absence of impulse and ingress noise.

- Select forward and reverse channel frequencies from the range specified in your channel plan.
- Verify that your cable network meets system requirements and Data-over-Cable Service Interface Specifications (DOCSIS) and/or EuroDOCSIS downstream and upstream specifications.
- Make sure that the site maintains an ambient temperature of 32 to 104°F (0 to 40°C), and keep the area around the chassis as free from dust as is practical.

AC Power

The AC input of the power supply module uses a power factor corrector that allows the Cisco uBR 3x10 RF Switch to operate on input voltage and frequency within the ranges of 100 to 240 VAC and 50 to 60 Hz.

**Note**

We recommend an uninterruptible power source to protect against power failures at your site. An AC-input power supply has an electrical current rating of less than 1 A.

See [Appendix A, “Specifications and Component Part Numbers,”](#) for system power specifications, including input voltage and operating frequency ranges.

DC Power

The DC input of the power supply module operates at -48 VDC input voltage and supplies +12.0 VDC power to the Cisco uBR 3x10 RF Switch’s internal components through the midplane.

**Note**

Each DC-input power supply has an electrical current rating of 0.7A, 20 VA. Use a minimum of 14 AWG (2.5 mm²) wire for the input to each DC-input power supply. The power input must be protected by a 15 A circuit breaker or fuse that is in compliance with your local electric regulations.

See [Appendix A, “Specifications and Component Part Numbers,”](#) for system power specifications, including input voltage and operating frequency ranges.

Site Environment

Table 2-1 lists the operating and nonoperating site temperature requirements. The following ranges are those within which the Cisco uBR 3x10 RF Switch continues to operate; however, a measurement that is approaching the minimum or maximum of a range indicates a potential problem. You can maintain normal operation by anticipating and correcting environmental anomalies before they approach a maximum operating range.

Table 2-1 Specifications for Operating and Nonoperating Environments

Specification	Minimum	Maximum
Temperature, ambient operating	32°F (0°C)	104°F (40°C)
Temperature, ambient nonoperating and storage	-4°F (-20°C)	149°F (65°C)

Site Configuration: Maintaining Normal Operation

Planning a proper location for the Cisco uBR 3x10 RF Switch and the layout of your equipment rack or wiring closet is essential for successful system operation. Equipment placed too close together or inadequately ventilated can cause system overtemperature conditions. In addition, chassis panels made inaccessible by poor equipment placement can make system maintenance difficult. Following are precautions that can help avoid problems during installation and ongoing operation.

General Precautions

Follow these general precautions when planning your equipment locations and connections:

- Use the **show environment** command regularly to check the internal system status. The environmental monitor continually checks the interior chassis environment; it provides warnings for high temperature and maximum and minimum voltages and creates reports on any occurrences. If warning messages are displayed, take immediate action to identify the cause and correct the problem.
- We recommend keeping the Cisco uBR 3x10 RF Switch off the floor and out of any area that tends to collect dust, excessive condensation, or water.
- Follow the ESD prevention procedures in the [“Preventing Electrostatic Discharge Damage” section on page 2-4](#) to avoid damage to equipment. Damage from static discharge can cause immediate or intermittent equipment failure.

Power Considerations

Follow these precautions and recommendations when planning power connections to a Cisco uBR 3x10 RF Switch:

- Check the power at your site before installation and periodically after installation to ensure that you are receiving clean power. Install a power conditioner, if necessary.
- Install proper grounding to avoid damage from lightning and power surges.

Provisioning the Headend

The following sections describe the provisioning required at the cable headend before you install the Cisco uBR 3x10 RF Switch.

Headend Certification

The cable headend plant must pass both analog and digital certification:

- In the United States, the Federal Communications Commission (FCC) mandates certification.
- For international certification, consult with local agencies for certification requirements.

Headend Wiring

This section provides guidelines for setting up the headend wiring and cabling at your site. When planning the location of the new system, consider the distance limitations for signaling, electromagnetic interference (EMI), and connector compatibility, as described in the following sections:

- Interference Considerations
- Distance Limitations and Interface Specifications

Interference Considerations

When wires are run for any significant distance in an electromagnetic field, interference can occur between the field and the signals on the wires. This fact has two implications for the construction of headend wiring:

- Bad wiring practice can result in radio interference emanating from the wiring, ingress noise, co-channel interference, and degraded or erratic universal broadband router performance.
- Strong EMI, especially when caused by lightning or radio transmitters, can destroy the signal drivers and receivers in the Cisco RF switch, and can even create an electrical hazard by conducting power surges through lines and into equipment. (Review the safety warnings in the [“Safety with Electricity”](#) section on page 2-3.)

If you use twisted-pair cable in your headend wiring with a good distribution of grounding conductors, the wiring is unlikely to emit radio interference. If you exceed the recommended distances, use a high-quality twisted-pair cable with one ground conductor for each data signal when applicable.

If wires exceed recommended distances, or if wires pass between buildings, give special consideration to the effect of a lightning strike in your vicinity. The electromagnetic pulse caused by lightning or other high-energy phenomena can easily couple enough energy into unshielded conductors to destroy electronic devices. If you have had EMI problems in the past, you might want to consult experts in electrical surge suppression and shielding.

Distance Limitations and Interface Specifications

The size of your networks and the distances between connections depend on the type of signal, the signal speed, and the transmission media (the type of cabling used to transmit the signals). For example, standard coaxial cable has a greater channel capacity than twisted-pair cabling. The distance and rate limits in the following descriptions are the IEEE recommended maximum speeds and distances for

signaling; however, you can usually get good results at speeds and distances far greater than these. For example, the recommended maximum rate for V.35 is 2 Mbps, and it is commonly used at 4 Mbps without any problems. If you understand the electrical problems that might arise and can compensate for them, you should get good results with rates and distances greater than those shown here; however, do so at your own risk.

**Caution**

We recommend that you do not exceed specified transmission rate and distance limits.

When preparing your site for network connections to the Cisco uBR 3x10 RF Switch, you must consider a number of factors related to each type of interface:

- The type of cabling required for each type of interface (fiber, thick or thin coaxial, shielded twisted-pair, or unshielded twisted-pair cabling)
- Distance limitations for each signal type
- The specific cables you need to connect each interface
- Any additional interface equipment you need, such as transceivers, hubs, switches, modems, CSUs, or DSUs
- Cable pinouts if you plan to build your cables

Equipment Racks

The rack-mounting hardware included with the Cisco uBR 3x10 RF Switch is suitable for most 19-inch equipment racks designed per EIA-310 or MIL-STD-189.

When planning your rack installation, follow these guidelines:

- Install the Cisco uBR 3x10 RF Switch in an open rack whenever possible. If installation in an enclosed rack is unavoidable, ensure that the rack has adequate ventilation.
- If you plan to use an equipment shelf, ensure that the shelf is constructed to support the weight and dimensions of the chassis.
- Always install heavier equipment in the lower half of a rack to maintain a low center of gravity and prevent the rack from falling.
- Ensure that you have access to the front and rear of the unit.
- Position the Cisco uBR 3x10 RF Switch close enough to the Cisco CMTS in which the cable interface line cards are installed to be sure you have enough cable to reach the furthest interfaces.
- Before using a specific rack, check for obstructions (such as a power strip) that could impair rack-mount installation.
 - If a power strip does impair a rear rack-mount installation, remove the power strip before installing the Cisco uBR 3x10 RF Switch in the rack, and replace it after the chassis is installed.
 - As an alternative, mount the Cisco uBR 3x10 RF Switch on an equipment shelf if the rack dimensions allow you to secure the router to the shelf and the overall configuration permits safe installation and access. However, we recommend rack-mounting the Cisco uBR 3x10 RF Switch.
- Review the precautions for avoiding overtemperature conditions in the [“Site Environment” section on page 2-6](#).
- To properly install the Cisco uBR 3x10 RF Switch chassis in a rack, refer to the instructions in the [“Rack-Mounting the RF Switch with the Cisco uBR10012 CMTS” section on page 3-3](#).

**Caution**

To prevent the chassis from overheating, never install the Cisco uBR 3x10 RF Switch in an enclosed rack or room that is not properly ventilated or air conditioned. The Cisco uBR 3x10 RF Switch overheats if the input air temperature reaches 105°F (41°C).

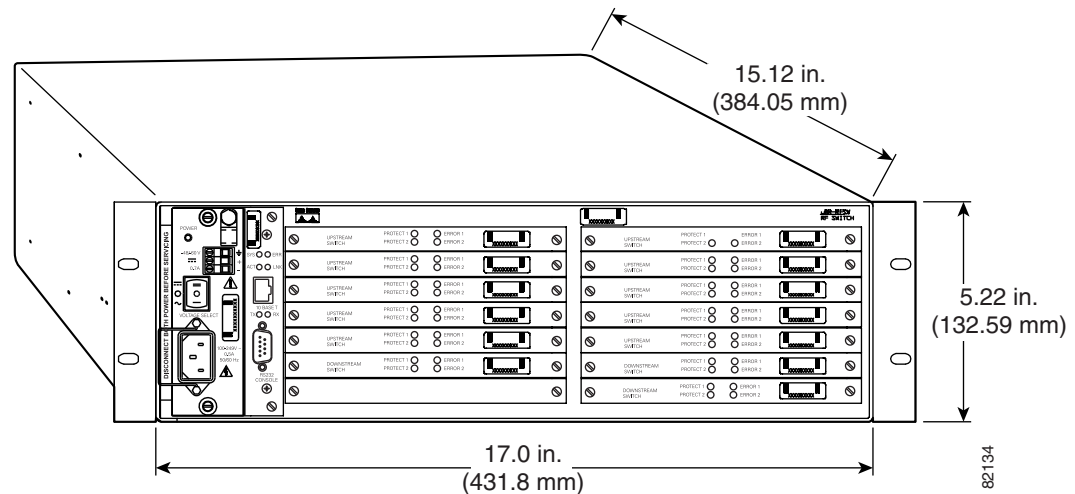
Figure 2-2 Dimensions

Tools for Installation

Your Cisco uBR 3x10 RF Switch is fully assembled at the factory; no assembly is required. However, you need the following tools and equipment to install rack-mount brackets on the Cisco uBR 3x10 RF Switch chassis, install the chassis in the rack, and if you are using nonprepopulated cable bundles, complete assembly of unterminated MCX connectors on the RF cable bundle:

- Number 2 Phillips screwdriver (extended length)
- 3/16-inch flat-blade screwdriver (extended length)
- 7/16-inch flat-blade screwdriver (extended length)
- 8-mm wrench or nut driver, or adjustable wrench (for connecting a grounding lug to a DC-input power supply only)
- 7-mm wrench or nut driver, or adjustable wrench (for connecting the DC-input power lead strain-relief cover to a DC-input power supply only)
- MCX connector removal tool (see [Figure 2-3](#)), for removing MCX connectors from header blocks and universal cable holders (UCHs)

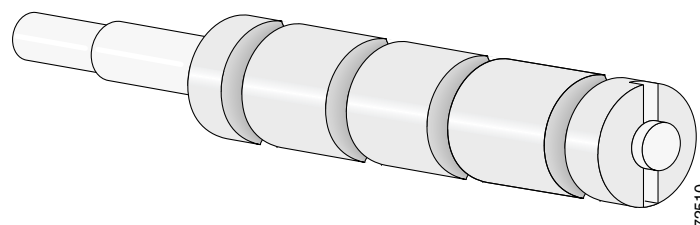
Figure 2-3 MCX Connector Removal Tool

- Cable management bracket (optional)

Figure 2-4 *Optional Cable Management Bracket for the Cisco uBR10012 Chassis*

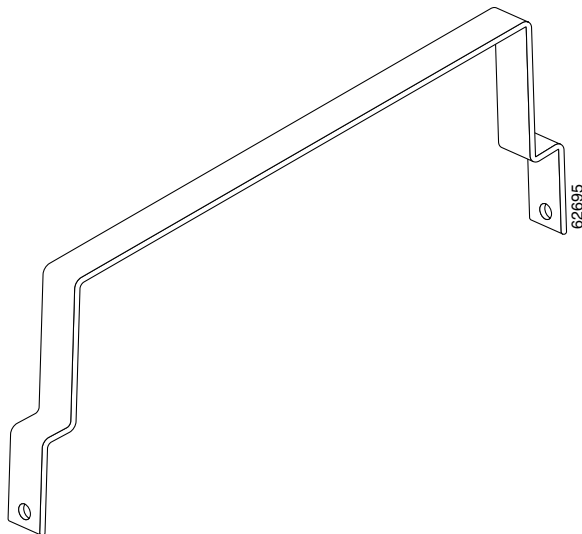

- Tape measure (optional)
- Level (optional)
- 14 American Wire Gauge (2.5 mm²) cable with a minimum of three conductors rated for at least 140°F (60°C) (for DC-input power supply installations only)
- Standard wire stripper (for grounding wire and DC-input power supply installations)
- Tape (for securing the handle of a DC circuit breaker in the OFF position when a DC-input power supply is powered down)

The rack-mount kit includes the following parts:

- Two rack-mount brackets for mounting the chassis in the rack
- Four M5 x 8-mm Phillips countersunk screws to secure the rack-mount brackets to the chassis

To verify your plant's RF setup, you need the following:

- Cisco uBR 3x10 RF Switch cabling bundles supplied by Cisco Systems, Inc. or WhiteSands Engineering, complete with header blocks and MCX connectors. For more detailed information, refer to the [“RF Cable Assemblies” section on page 4-4](#) and [“Specifications and Component Part Numbers” section on page A-1](#).
- Vecima HD4040 series IF-to-RF upconverter (when needed)
- RF spectrum analyzer
- For coaxial cabling:
 - Diplex filters and splitters
 - Coaxial cable crimping tool
 - New coaxial cable
 - Coaxial jumpers that are at least two to three feet long (maximum of five feet)
- For fiber networks, fiber-optic laser receivers for each upstream channel
- Assorted RF attenuators (with at least two 20-dB attenuators)

In addition, you might need the following cables:

- Straight through cable
- Rollover cable
- Crossover cable

Verifying the Shipping Container Contents

When you receive your Cisco uBR 3x10 RF Switch, use the following procedure to check the contents of the shipping container. Use the installation checklist and the component list to ensure that you received all the components you ordered.

**Note**

Do not discard the shipping container. You will need the container if you move or ship your Cisco uBR 3x10 RF Switch in the future.

-
- Step 1** Verify that the following are included in the shipping container (the accessories box might be separate):
- One Cisco uBR 3x10 RF Switch chassis containing all the components you ordered for your system
 - One or more accessories boxes (some or all might be shipped separately)
- Step 2** Check the contents of the accessories box against the installation checklist and the packing slip to verify that you received all listed equipment, which should include everything listed in [Table 2-2](#) and any ordered Cisco IOS software or other documentation.
- Step 3** After provisioning the headend as documented in the next section, refer to the [“Rack-Mounting the RF Switch with the Cisco uBR10012 CMTS”](#) section on [page 3-3](#) to begin the installation.
-

Table 2-2 Cisco RF Switch Component List

Description	Received
Cisco uBR 3x10 RF Switch—contains one Ethernet controller, one power supply, 10 upstream switch cards, three downstream switch cards, and one blank panel.	
<p>The following accessories may arrive in separate shipping containers:</p> <ul style="list-style-type: none"> • Rack-mount kit—Two rack-mount brackets and four M5x8-mm Phillips flathead screws, four M4 x 6-mm Phillips panhead screws, and four 10/32 x 3/8-inch slotted binderhead screws. • AC-input power cable • MCX connector removal tool • Documentation¹, including the following: <ul style="list-style-type: none"> – <i>Cisco uBR 3x10 RF Switch Switch Documentation Roadmap</i>—Pointing you directly to the location of related documentation on Cisco.com – <i>Rack-Mounting the Cisco RF Switch with the Cisco uBR10012 CMTS</i> – <i>Rack-Mounting the Cisco RF Switch with the Cisco uBR7246VXR CMTS</i> – <i>Cabling the Cisco uBR 3x10 RF Switch</i> – <i>Regulatory Compliance and Safety Information for the Cisco RF Switch</i> – Cisco Information Packet 	

1. Titles and quantities of documents will vary depending on the configuration that you choose. You must order Cisco IOS and other documentation that isn't automatically shipped with the product when you order the hardware.



CHAPTER 3

Installing the Cisco RF Switch

This chapter explains the procedures to install and connect the Cisco uBR 3x10 RF Switch. The chapter contains the following sections:

- [Installation Checklist, page 3-1](#)
- [Rack-Mounting the RF Switch with the Cisco uBR10012 CMTS, page 3-3](#)
- [Rack-Mounting the RF Switch with the Cisco uBR7246VXR CMTS, page 3-9](#)
- [Installing the Cisco uBR 3x10 RF Switch on a Workbench or Tabletop Environment, page 3-13](#)
- [Connecting Power, page 3-14](#)

Installation Checklist

A rack-mount kit is included in the shipping container. The rack-mount brackets in the kit are for mounting the Cisco uBR 3x10 RF Switch in a standard, 19-in.-wide, 4-post equipment rack.



Note

The rack-mount brackets are not suitable for use with other racks, such as 23-in. telco racks.

If you are installing an equipment shelf or using mounting hardware other than that supplied with the chassis, review the guidelines in the “[Equipment Racks](#)” section on page 2-8.

If you do not plan to install your Cisco uBR 3x10 RF Switch in an equipment rack, proceed to the “[Installing the Cisco uBR 3x10 RF Switch on a Workbench or Tabletop Environment](#)” section on page 3-13.

To assist you with your installation and provide a historical record of what was done, and by whom, use the Installation Checklist in [Table 3-1 on page 3-2](#). Print a copy of this checklist and indicate when each procedure or verification is completed.

Checklist

Table 3-1 *Installation Checklist*

Task	Verified by	Date
Cisco uBR 3x10 RF Switch and all accessories unpacked		
Types and numbers of interfaces verified		
Brackets installed		
Cisco uBR 3x10 RF Switch mounted in rack (optional)		
Cisco uBR 3x10 RF Switch chassis grounding lug installed and grounding wire connected		
Optional cable management bracket installed on the Cisco uBR10012 CMTS		
AC power cable or DC power leads connected to power source and Cisco uBR 3x10 RF Switch; cables secured		
Captive installation screws on Ethernet controller, power supply, and upstream and downstream switch cards checked		
Network interface cables and devices connected		
ASCII terminal attached to console port		
Console port set for 9600 baud, 8 data bits, no parity, and 1 stop bit (9600 8N1)		
System power turned on (DC OK LED is on)		
System boot complete (I/O controller enabled LED is on)		
Ethernet controller, power supply and upstream and downstream switch cards operational		
System ready for global and interface-specific configuration		

Notes:

Rack-Mounting the RF Switch with the Cisco uBR10012 CMTS

Depending on which CMTS you use (Cisco uBR10012 CMTS or Cisco uBR7246VXR CMTS) the brackets are attached to the front or rear of the RF switch chassis, and the chassis is mounted at the front or the rear of the rack. [Figure 3-1](#) and [Figure 3-2](#) illustrate the Cisco uBR10012 CMTS configuration.

For information about installing the RF switch with the Cisco uBR7246VXR CMTS see [Rack-Mounting the RF Switch with the Cisco uBR7246VXR CMTS, page 3-9](#).

The inside width between the posts or mounting strips (left and right) must be at least 17 in. (44.45 cm). Some equipment racks provide a power strip along the length of one of the mounting strips. If your rack has this feature, consider the position of the strip when planning fastener points and ensure that you will be able to pull any components straight out of their respective slots.

The inlet and exhaust ports for cooling air are located on the right and left of the chassis, respectively, so multiple Cisco uBR 3x10 RF Switches can be stacked in a rack with little or no vertical clearance.



Note For information on the Vecima HD4040 series If-to-RF upconverters, go to the following URL:

<http://www.vecima.com>



Note If you are installing an AC shelf in the same rack with the Cisco uBR10012 CMTS, refer to the documentation included with the AC shelf. The shelf is usually positioned at the bottom of the rack.

Tools and Fasteners

These tools and fasteners are required to install the mounting brackets on the Cisco uBR 3x10 RF Switch and install the switch in a rack. Some items are included in the kit.

Bracket Installation

- Four rack-mount brackets, (included)
- Eight M5 x 8 mm Phillips countersunk screws (included)—To install the brackets on the switch
- Number 2 Phillips screwdriver (extended length)

Rack Installation

- Eight 1/32 x 3/8 slotted screws (included)—To install the switch in the rack
- 7/16-inch flat-blade screwdriver (extended length)

Chassis Grounding

- Grounding lug (included)
- Four M5 (metric) hex-head screws with locking washers
- 8-mm wrench or nut driver (or adjustable wrench)
- Drying device
- Grounding wire (4 AWG recommended)—The length of the grounding wires depends on the location of your router within the site and its proximity to proper grounding facilities.
- Heat shrink tubing—One segment, 1.5 in. (3.8 cm) length by 0.5 in. (1.2 cm) diameter

Cisco uBR10012 CMTS, Cisco uBR10-MC5X20S/U/H Cable Interface Line Cards, and Two Cisco uBR 3x10 RF Switches

This sample configuration shows the Cisco uBR10012 router with Cisco uBR10-MC5X20S/U/H cable interface line cards installed, and two Cisco uBR 3x10 RF Switches mounted flush front. See [Figure 3-1](#).

Note

An upconverter is not required when using the Cisco uBR-MC5x20S/U/H cable interface line card.

Figure 3-1 Sample Configuration Using Two Cisco uBR 3x10 RF Switches

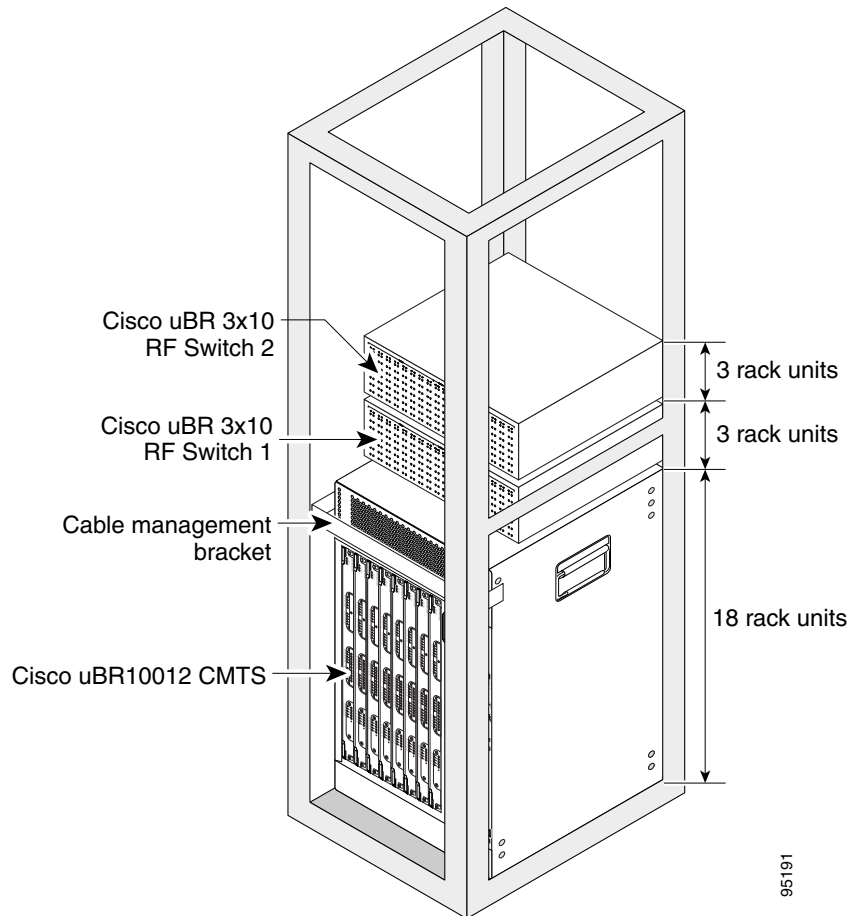

Cisco uBR10012 CMTS, Cisco uBR10-MC28C Cable Interface Line Cards, One RF Switch, and One Upconverter

This sample configuration shows the Cisco uBR10012 CMTS with Cisco MC28C cable interface line cards installed, one Cisco uBR 3x10 RF Switch mounted flush front, and one Vecima HD4040 series upconverter. See [Figure 3-2](#).



Note

An upconverter is required when you are using either the Cisco uBR-MC16C, E, S, line card or the Cisco uBR-MC28C line Card in this configuration.

Figure 3-2 Sample Configuration Using One Cisco uBR 3x10 RF Switch

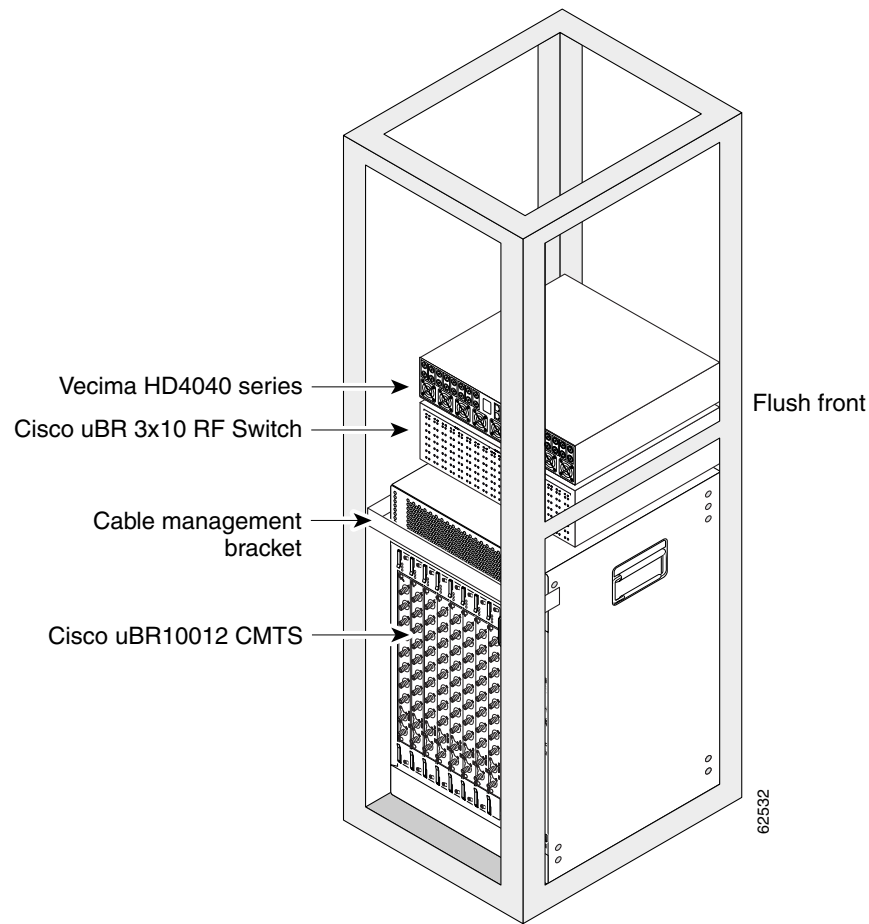

Attaching the Brackets for the Cisco uBR10012 CMTS

This section explains how to attach the rack-mount brackets to a Cisco uBR 3x10 RF Switch for flush-front installations as shown in [Figure 3-1](#) and [Figure 3-2](#).



Tip

We recommend that you install the rack-mount brackets on the front portion of the Cisco uBR 3x10 RF Switch so that the MCX connector side of the RF switch (coinciding with the RF cable interfaces on the cards in the Cisco uBR10012 router) face the rear of the rack.

Equipment

- Two brackets (Cisco part number 74-2620-01)
- Four M5 x 8-mm Phillips countersunk screws
- Number 2 Phillips screwdriver

To install the rack-mount brackets for a flush-front configuration, complete the following steps:

Step 1 Locate the threaded holes in the front sides of the chassis.

Figure 3-3 *Installing the Rack-Mount Brackets on the Cisco uBR 3x10 RF Switch (Front Mount)*

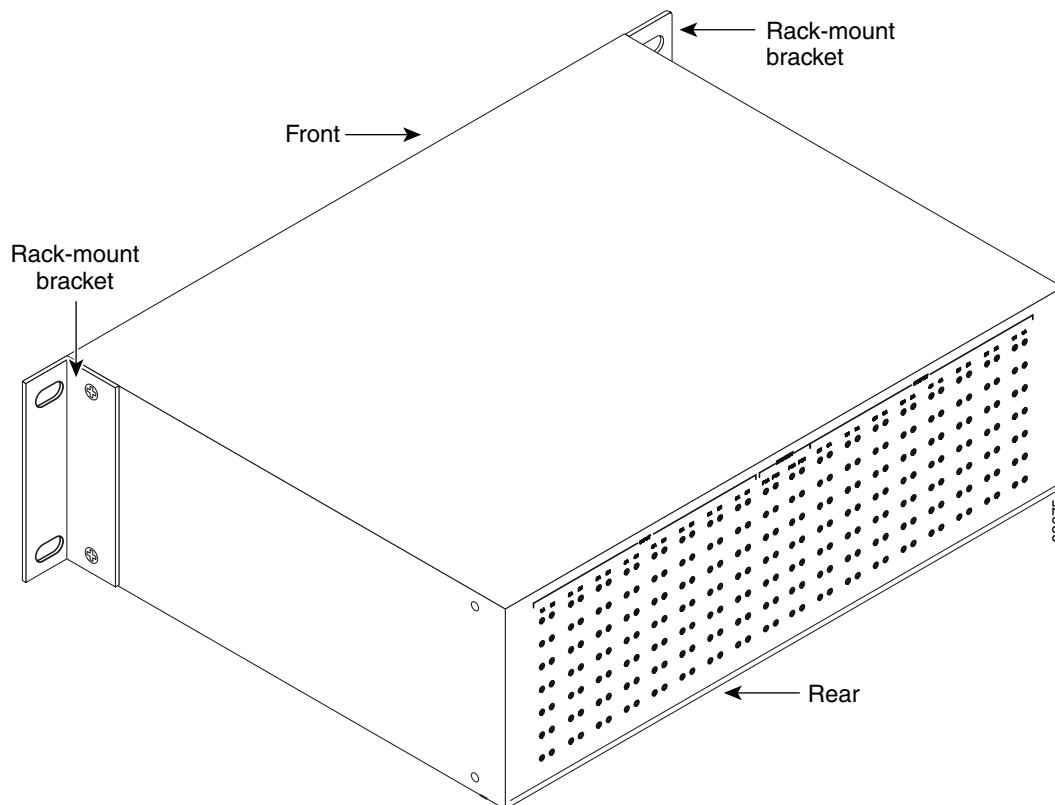

Step 2 Align the first rack-mount bracket with the threaded holes in the front right side of the chassis. Align the bracket with the chassis as shown in [Figure 3-3](#) on page 3-6.

- Step 3** Thread the M5 x 8-mm Phillips countersunk screws through the rack-mount bracket and into the side of the chassis. Use a number 2 Phillips screwdriver to tighten the screws.
- Step 4** Repeat [Step 1](#) through [Step 3](#) for the other rack-mount bracket.
-

Installing the RF Switch in the Rack with the Cisco uBR10012 CMTS

To prevent injury, review the safety precautions in [Chapter 2, “Preparing for Installation,”](#) before installing the Cisco uBR 3x10 RF Switch in a rack.

**Note**

For this configuration, the Cisco uBR 3x10 RF Switch is placed so that the MCX connection side of the switch is facing in the same direction as the cable interface line cards.

**Caution**

Because the brackets support the weight of a fully populated chassis (36.6 lb [16.6 kg]), be sure to use all four screws to fasten the two rack-mount brackets to the rack posts.

**Note**

If you are installing two RF switches, leave one rack unit (1 RU) between the two switches.

Equipment

- Four 1/32 x 3/8 slotted screws (eight for two RF switches)
- 7/16-inch flat-blade screwdriver (extended length)

To install the chassis in the rack, refer to the sample configuration appropriate to your installation (see [Figure 3-1 on page 3-4](#), or [Figure 3-2 on page 3-5](#) and complete the following steps:

- Step 1** Ensure that all the components in the RF switch are securely installed (captive screws are tight).
- Step 2** Make sure that the rack is stabilized, if necessary.
-  **Tip** Two people should perform [Step 3](#) through [Step 6](#).
- Step 3** Position the RF switch so that the upstream and downstream modules are facing the front of the router.
- Step 4** Slide the switch into the rack, pushing it back until the brackets (installed at the front of the RF switch chassis) meet the mounting strips or posts on both sides of the equipment rack.
- Step 5** While keeping the brackets flush against the posts or mounting strips, position the RF switch so the holes in the brackets are aligned with those in the mounting strips.
- Step 6** Insert all four screws (two on each side) through the brackets and into the mounting strip and tighten. Insert the bottom screws first.
- Step 7** Repeat [Step 3](#) through [Step 6](#) for the second RF switch, if necessary.
-

Installing the Cable Management Bracket on the Cisco uBR10012 Router

The cable management bracket for Cisco uBR10012 CMTS chassis is enclosed in the shipping container with your Cisco uBR 3x10 RF Switch. (See [Figure 3-4](#).) Installation of the bracket is optional, however, we recommend using this bracket to ensure proper airflow in the chassis.

Ensure that the bracket is connected before you proceed with connecting RF cables to the cable interface line cards installed in your Cisco uBR10012 chassis. See [Figure 3-1](#) on page 3-4 and [Figure 3-2](#) on page 3-5 for illustrations of the cable management bracket's location on the Cisco uBR10012 chassis.

Equipment

- Cable management bracket (Cisco part number 700-14066-01)
- Two M5 x 8-mm Phillips countersunk screws
- Number two Phillips screwdriver (extended length)

Figure 3-4 Optional Cable Management Bracket for the Cisco uBR10012 CMTS Chassis

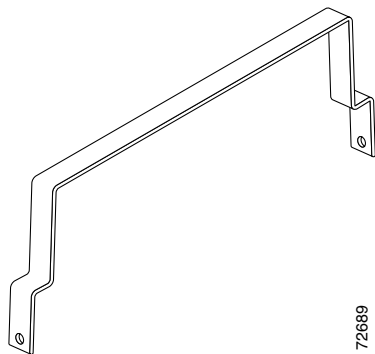

To install the cable-management bracket, complete the following steps:

-
- Step 1** Locate the threaded holes in the top-right-rear and top-left-rear side of the Cisco uBR10012 chassis (spanning the width of the cable interface line cards on the chassis).
 - Step 2** Align the cable-management bracket with one set of threaded holes at the top of the Cisco uBR10012 chassis.
 - Step 3** Thread M5 x 8-mm Phillips countersunk screws through the bracket and into the chassis.
 - Step 4** Use a number 2 Phillips screwdriver to tighten the screws.
-

Rack-Mounting the RF Switch with the Cisco uBR7246VXR CMTS

Depending on which CMTS you use (Cisco uBR10012 CMTS or Cisco uBR7246VXR CMTS) the brackets are attached to the front or rear of the RF switch chassis, and the chassis is mounted at the front or the rear of the rack. [Figure 3-3](#) illustrates Cisco uBR7246VXR CMTS configurations.

For information about installing the RF switch with the Cisco uBR10012 CMTS see [Rack-Mounting the RF Switch with the Cisco uBR10012 CMTS, page 3-3](#).

The inside width between the posts or mounting strips (left and right) must be at least 17 in. (44.45 cm). Some equipment racks provide a power strip along the length of one of the mounting strips. If your rack has this feature, consider the position of the strip when planning fastener points and ensure that you will be able to pull any components straight out of their respective slots.

The inlet and exhaust ports for cooling air are located on the right and left of the chassis, respectively, so multiple Cisco uBR 3x10 RF Switches can be stacked in a rack with little or no vertical clearance.

**Note**

For information on the Vecima HD4040 series If-to-RF upconverters, go to the following URL:

<http://www.vecima.com>

Tools and Fasteners

These tools and fasteners are required to install the mounting brackets on the Cisco uBR 3x10 RF Switch and install the switch in a rack. Some items are included in the kit.

Bracket Installation

- Four rack-mount brackets, (included)
- Eight M5 x 8-mm Phillips countersunk screws (included)—to install the brackets on the switch
- Number 2 Phillips screwdriver (extended length)

Rack Installation

- Eight 1/32 x 3/8 slotted screws (included)—to install the switch in the rack
- 7/16-inch flat-blade screwdriver (extended length)

Chassis Grounding

- Grounding lug (included)
- Four M5 (metric) hex-head screws with locking washers
- 8-mm wrench or nut driver (or adjustable wrench)
- Drying device
- Grounding wire (4 AWG recommended)—The length of the grounding wires depends on the location of your router within the site and its proximity to proper grounding facilities.
- Heat shrink tubing—One segment, 1.5 in. (3.8 cm) length by 0.5 in. (1.2 cm) diameter

Cisco uBR7246VXR CMTS, Cisco uBR-MC-16x, Cisco uBR-MC-28C, Cisco uBR 3x10 RF Switches, and Upconverters

Figure 3-5 illustrates sample configurations using the Cisco uBR 3x10 RF Switch and the Cisco uBR7246VXR router. Sample 1 shows the Cisco uBR7246VXR with Cisco uBR-MC16C, E, S, or X cable interface line cards installed. Sample 2 shows the Cisco uBR7246VXR with Cisco uBR-MC28C cable interface line cards installed. Upconverters are required in these samples.



Note

Sample 2 shows an Ethernet switch located above the Vecima upconverters. The switch can be located in the rack if there is room or in another rack or location.

Figure 3-5 Sample Configurations for the Cisco uBR7246VXR CMTS

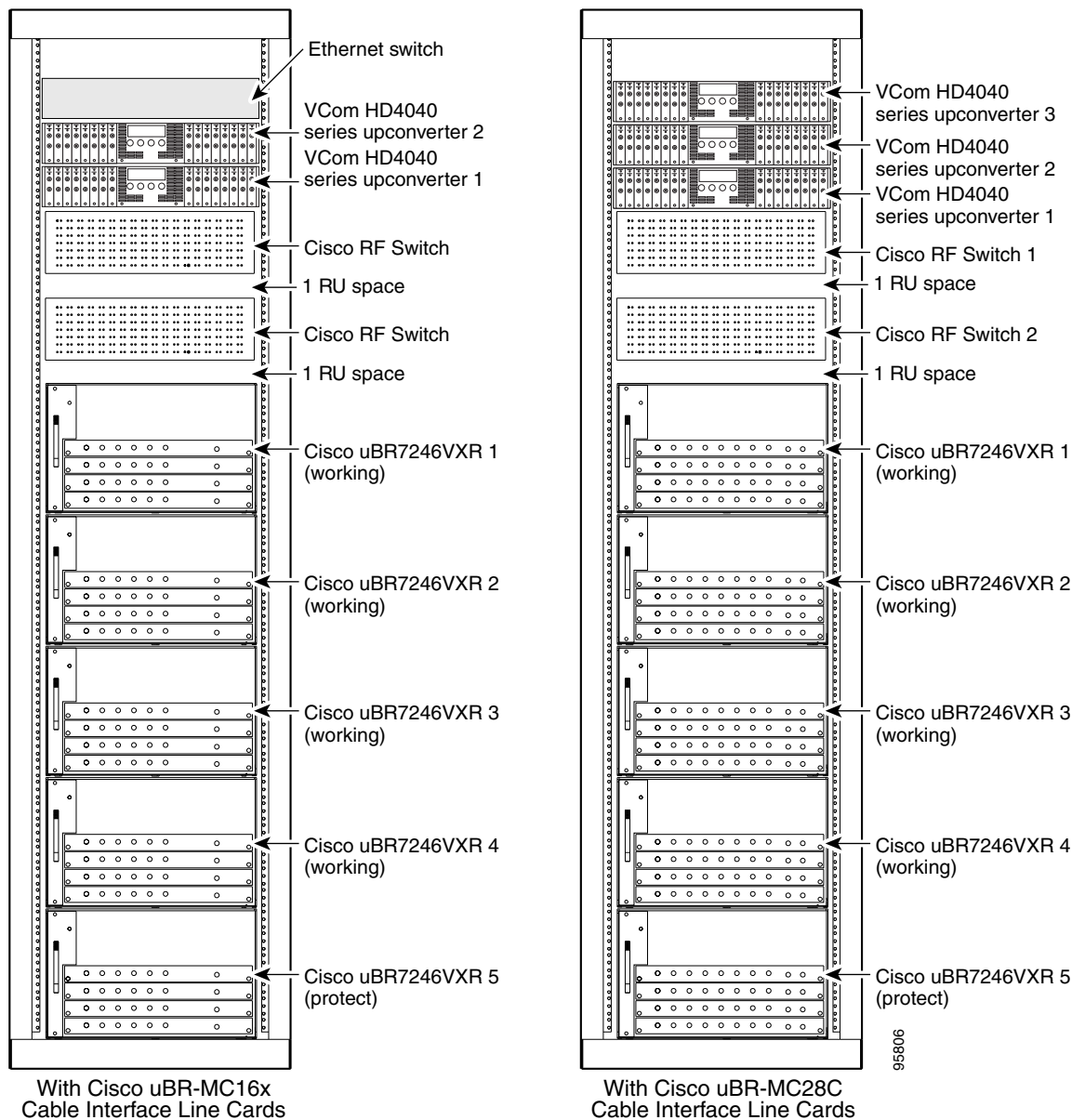

Installing the Brackets on the Cisco uBR 3x10 RF Switch Chassis

This section explains how to install the rack-mount brackets on a Cisco uBR 3x10 RF Switch for flush-rear installations as shown in [Figure 3-5 on page 3-10](#). We recommend that you install the rack-mount brackets so that the MCX connector side of the RF switch (coinciding with the RF cable interfaces on the Cisco uBR7246VXR CMTS) faces the rear of the rack.

Equipment

- Two Brackets (Cisco part number 74-2620-01)
- Four M5 x 8-mm Phillips countersunk screws
- Number 2 Phillips screwdriver

To install the rack-mount brackets on the chassis for a flush-rear configuration, complete the following steps:

- Step 1** Locate the threaded holes on the rear sides of the chassis.
- Step 2** Align the first rack-mount bracket with the threaded holes in the rear right side of the chassis. See [Figure 3-6](#).
- Step 3** Thread the M5 x 8-mm Phillips countersunk screws through the rack-mount bracket and into the side of the chassis. Use a number 2 Phillips screwdriver to tighten the screws.
- Step 4** Repeat [Step 1](#) through [Step 3](#) for the other rack-mount bracket.

Figure 3-6 *Installing the Rack-Mount Brackets on the Cisco uBR 3x10 RF Switch (Rear Mount)*

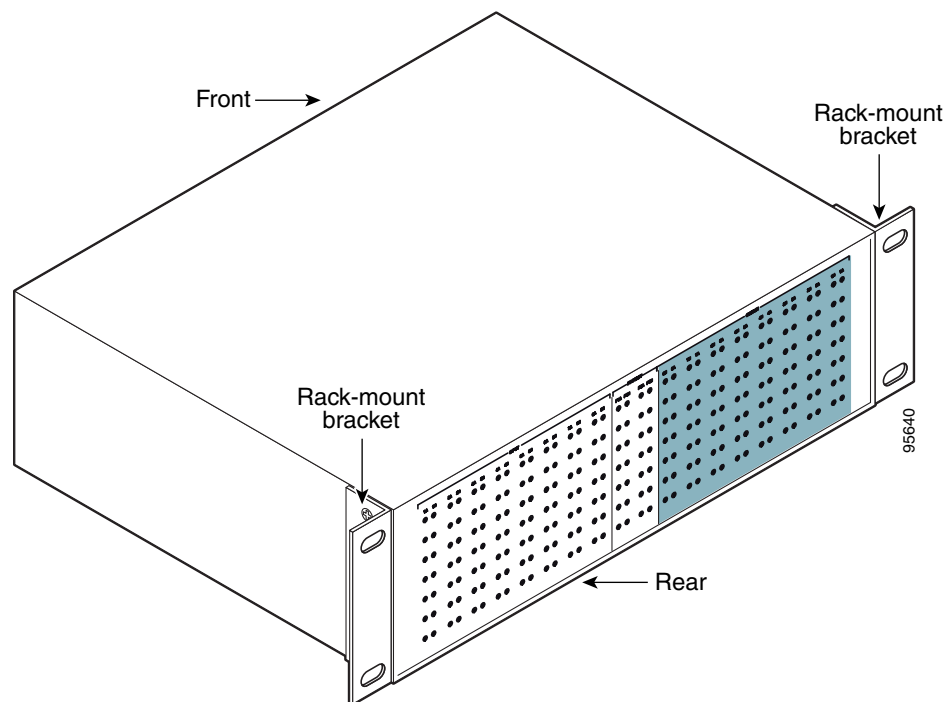

Installing the Chassis in the Rack

To prevent injury, review the safety precautions in [Chapter 2, “Preparing for Installation,”](#) before installing the Cisco uBR 3x10 RF Switch in a rack.





Caution

Because the brackets support the weight of a fully populated chassis (36.6 lb [16.6 kg]), be sure to use all four screws to fasten the two rack-mount brackets to the rack posts.

Equipment

- Four 1/32 x 3/8 slotted screws
- 7/16-inch flat-blade screwdriver

To install the chassis in the rack, refer to the example configuration appropriate to your installation (see [Figure 3-3 on page 3-6](#)), and complete the following steps:

-
- Step 1** On the RF switch, ensure that all captive screws on the Ethernet controller, power supply, and all upstream and downstream switch modules in the RF switch are tightened.
- Step 2** Ensure that the path to the rack is unobstructed. If the rack is on wheels, ensure that the brakes are engaged or that the rack is otherwise stabilized.
-
-  **Tip** Two people should perform Step 3 through Step 6.
-
- Step 3** Position the chassis so that the front end is closest to you; then lift the chassis and move it to the rack.
- Step 4** Slide the chassis into the rack, pushing it back until the brackets (installed at the front or rear of the chassis) meet the mounting strips or posts on both sides of the equipment rack.
-
-  **Tip** Remember to leave 1 RU between the Cisco uBR7246VXR router and the Cisco uBR 3x10 RF Switch. This space is used for cable management.
-
- Step 5** While keeping the brackets flush against the posts or mounting strips, position the RF switch so that the holes in the brackets are aligned with those in the mounting strips.
- Step 6** Insert all four 1/32 x 3/8 slotted screws through the brackets and into the mounting strip.
-
-  **Tip** Insert the bottom screws first.
-
- Step 7** Tighten all the screws.
-

Installing the Cisco uBR 3x10 RF Switch on a Workbench or Tabletop Environment

The Cisco uBR 3x10 RF Switch should already be in the area where you will install it, and your installation location should already be determined. If not, refer to the [“Site Requirements” section on page 2-5](#).

When installing the RF switch on a workbench or tabletop, ensure that the surface is clean and in a safe location and that you have considered the following:

- Installing the RF switch in a workbench or tabletop environment should be performed only if the chassis is connected to an AC power source. DC power leads required to deliver power to the chassis can suffer undue strain if installed in a workbench on tabletop environment.
- The Cisco uBR 3x10 RF Switch requires at least 3 in. (7.72 cm) of clearance at the inlet and exhaust vents (the right and left sides of the RF switch).
- The Cisco uBR 3x10 RF Switch should be installed off the floor. (Dust that accumulates on the floor is drawn into the interior of the chassis. Excessive dust inside the RF switch causes overtemperature conditions and component failures.)

To install on a workbench or tabletop, complete the following steps:

-
- Step 1** Remove any debris and dust from the tabletop or workbench and the surrounding area. Also make sure that the path between the Cisco uBR 3x10 RF Switch and its new location is unobstructed.
- Step 2** Ensure that all the components in the switch are secure and that the captive installation screws are tightened.
- Step 3** Carefully lift the chassis and place it on the tabletop or workbench.



Caution

The Cisco uBR 3x10 RF Switch weighs 36.6 lbs (16.6 kg.) with all the components installed.

Connecting Power

This section includes the following procedures.

- [Grounding the Cisco uBR 3x10 RF Switch, page 3-14](#)
- [Connecting AC Power to the Power Supply, page 3-16](#)
- [Connecting DC Power to the Power Supply, page 3-17](#)



Warning

Before working on equipment that is connected to power lines, remove jewelry (including rings, necklaces, and watches). Metal objects will heat up when connected to power and ground and can cause serious burns or weld the metal object to the terminals. Statement 43.



Warning

This equipment is intended to be grounded to comply with emission and immunity requirements. Ensure that the switch functional ground lug is connected to earth ground during normal use. Statement 1064



Warning

This unit might have more than one power supply connection. All connections need to be removed to de-energize the unit. Statement 1028

Before connecting power and turning on the Cisco uBR 3x10 RF Switch, you must provide an adequate ground connection for your system. Proceed to the following section, “[Grounding the Cisco uBR 3x10 RF Switch](#),” for a description of the tools you need to connect the required grounding wire to the RF switch. Then, if you intend to connect AC power to the Cisco uBR 3x10 RF Switch power supply, proceed to the “[Connecting AC Power to the Power Supply](#)” section on page 3-16. Otherwise, to connect DC power to the RF switch power supply, proceed to the “[Connecting DC Power to the Power Supply](#)” section on page 3-17.

Grounding the Cisco uBR 3x10 RF Switch

Before connecting power and turning on the Cisco uBR 3x10 RF Switch, you must provide an adequate ground connection for your system. Earth grounding holes are provided on the left-side panel (power supply side) of the RF switch chassis, approximately three inches back from the front panel. See [Figure 3-7 on page 3-15](#)



Warning

Use copper conductors only. Statement 1025.



Warning

This equipment must be grounded. Never defeat the ground conductor or operate the equipment in the absence of a suitably installed ground conductor. Contact the appropriate electrical inspection authority or an electrician if you are uncertain that suitable grounding is available. Statement 1024.



Warning

When installing or replacing the unit, the ground connection must always be made first and disconnected last. Statement 1046.

Tools and Equipment

- Grounding lug (included)—The grounding lug must have two M5 screw holes with 0.625 to 0.75 in. (15.86 to 19.05 mm) spacing between them.
- Two M5 (metric) hex-head screws with locking washers.
- 8-mm wrench or nut driver (or adjustable wrench)
- Grounding wire (4 AWG recommended)—The length of the grounding wires depends on the location of your router within the site and its proximity to proper grounding facilities.
- One segment of 1.5 in. (3.8 cm) length of 0.5 in. (1.2 cm) diameter heatshrink tubing.
- Heating device for the heatshrink tubing.



Note

The hex-head screws with locking washers, grounding wire, and heatshrink tubing are not available from Cisco Systems. You must obtain them from an electrical-connector vendor.

To connect the grounding wire to the Cisco uBR 3x10 RF Switch:

- Step 1** Ensure that the Cisco uBR 3x10 RF Switch is powered off and that you have disconnected the AC power cord or DC power leads from the power supply.
- Step 2** Strip approximately 0.75 in. (2 cm) of shielding from one end of the grounding wire.
- Step 3** Insert the stripped end of the grounding wire into the open end of the grounding lug and crimp the grounding lug securely to the grounding wire.
- Step 4** Slide the segment of heatshrink tubing over the joint of the grounding lug and grounding wire so that the exposed connection is covered.
- Step 5** Shrink the tubing in place using a suitable heating device.
- Step 6** Attach the grounding lug to the power-supply side of the Cisco uBR 3x10 RF Switch chassis using the two M5 hex-head screws.
- Step 7** Connect the other end of the grounding wire to an appropriate ground source.

Figure 3-7 Chassis Grounding Location

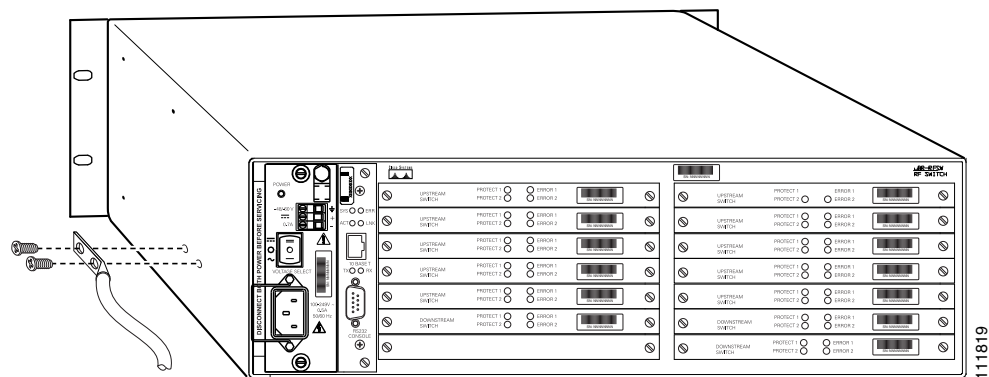

Connecting AC Power to the Power Supply

Equipment

- AC power cord



Warning

The device is designed to work with TN power systems. Statement 19.

- Step 1** Ensure that the power switch on the power supply is in the OFF (0) position.
- Step 2** Slide the cable-retention clip to the left, away from the AC receptacle, and plug in the power cable.
- Step 3** Secure the cable in the power supply AC receptacle by sliding the cable-retention clip to the right until it fits around the connector. The cable-retention clip provides strain relief for the AC power cable. (See [Figure 3-8](#).)



Note

For additional AC power cable strain relief, secure the cable to the power supply handle by inserting a nylon cable tie through the hole in the handle and around the cable.

- Step 4** Plug the AC power supply cable into the AC power source.
- This completes the procedure for connecting AC-input power.



Note

Wait until the system has been cabled before turning on the power supply. See the [“Powering On the RF Switch”](#) section on page 5-26

Figure 3-8 Connecting AC Power

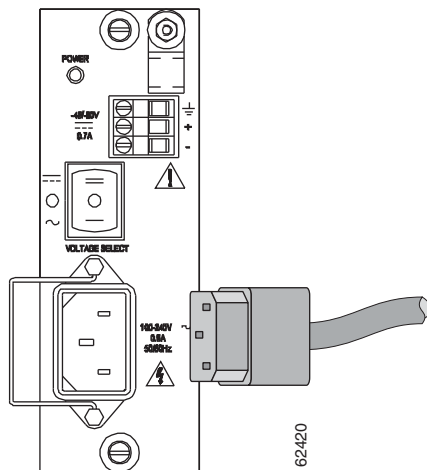

Connecting DC Power to the Power Supply

**Warning**

Before performing any of the following procedures, ensure that power is removed from the DC circuit. Statement 1003.

**Warning**

A readily accessible two-poled disconnect device must be incorporated in the fixed wiring. Statement 1022.

**Warning**

This product requires short-circuit (overcurrent) protection, to be provided as part of the building installation. Install only in accordance with national and local wiring regulations. Statement 1045.

**Note**

The color coding of the DC-input power supply leads depends on the color coding of the DC power source at your site. Typically, green or green-yellow is used for ground, black is used for +48V (return), and red or white is used for -48V. Ensure that the lead color coding you choose for the DC-input power supply matches lead color coding used at the DC power source.

**Caution**

Each DC-input power supply has an electrical current rating of 0.7 A, 20 VA. Use a minimum of 14 AWG (2.5 mm²) wire for the input to each DC-input power supply. The power input must be protected by a 15 A circuit breaker or fuse that is in compliance with your local electric regulations.

Equipment

- 14 AWG (2.5 mm²) wire
- Wire stripper
- AC to DC power source
- 7/16-inch flat-blade screwdriver

- Step 1** Ensure that the -48V and +48V leads are disconnected from the power source.
- Step 2** Check that the power switch on the power supply is in the OFF (0) position.
- Step 3** Ensure that the unit is properly grounded. See the [“Grounding the Cisco uBR 3x10 RF Switch” section on page 3-14](#).
- Step 4** Using a wire stripper, strip approximately 0.25 in. (7 mm) from the -48V and +48V leads.
- Step 5** Insert the stripped end of the +48V lead all the way into the +48V lead receptacle and tighten the receptacle screw using the same 3/16-inch flat-blade screwdriver.
- Step 6** Repeat [Step 4](#) and [Step 5](#) for the -48V lead.

**Caution**

If any exposed wire at the stripped end of a lead is visible after inserting the lead into its receptacle, remove the lead from the receptacle, use the wire stripper to cut the stripped end of the lead, and repeat [Step 4](#) and [Step 5](#), if necessary.

- Step 7** Tighten the receptacle screws and nuts for the +48V and -48V VDC input leads.
- Step 8** Run the +48V and -48V leads through the strain-relief on the top of the power supply faceplate and connect the leads to the DC power supply (+48V and -48V).
- Step 9** Adjust the voltage on the DC power supply to approximately -48V VDC.



Note Wait until the system has been cabled before turning on the power supply. See the “[Powering On the RF Switch](#)” section on page 5-26.

Figure 3-9 Connecting DC Power

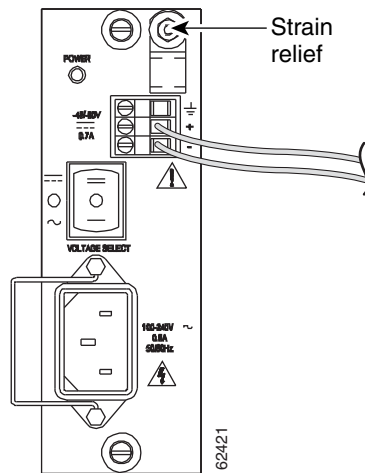



CHAPTER 4

Cabling the RF Switch With the Cisco uBR10012 CMTS Cable Interface Line Cards

This chapter provides information about connecting cables between the Cisco uBR 3x10 RF Switch and working and protect cable interface line cards in a Cisco uBR10012 CMTS.

This chapter contains the following sections:

- [Protection Scheme for the Cisco uBR10012 CMTS, page 4-1](#)
- [RF Cable Assemblies, page 4-4](#)
- [RF Cable Assemblies for Cisco uBR10-MC5X20S/U/H Line Cards, page 4-6](#)
- [Installing the Header Blocks on the Cisco uBR 3x10 RF Switch, page 4-9](#)
- [Mapping the RF Cables from the Working and Protect Line Cards \(MC16x, MC28C\) to the Cisco uBR 3x10 RF Switch, page 4-10](#)
- [Connecting the RF Cables \(MC16x, MC28C Line Cards\), page 4-15](#)
- [Mapping the Working and Protect Cisco uBR10-MC5X20S/U/H Line Cards RF Cables to the RF Switch, page 4-21](#)
- [Connecting the RF Cables \(Cisco uBR10-MC5X20S/U/H\), page 4-26](#)
- [Powering On the RF Switch, page 4-31](#)

Protection Scheme for the Cisco uBR10012 CMTS

The N+1 redundancy protection scheme you select for your system depends largely on the number and type of cable interface line cards you have installed in your Cisco uBR10012 router. The 7+1 eight-card redundancy scheme supports redundancy among the cable interface line cards installed in a fully populated Cisco uBR10012 router. Other redundancy schemes are designed to support partial cable interface line card population in a Cisco uBR10012 router.



Note

We recommend that the protect card be installed in slot 5/0 because this slot is directly below the PROTECT section on the RF switch.

Cisco uBR 3x10 RF Switch with the Cisco uBR-LCP2-MC16x (C, E, S) or MC28C Cable Interface Line Cards

A single Cisco uBR10012 router supports:

- Up to eight Cisco uBR10-LCP2-MC16C, E, or S cable interface line cards, each featuring one downstream and six upstream cable interfaces for a total of 8 downstream and 48 upstream interfaces in the chassis.
- Up to eight Cisco uBR10-LCP2-MC28C cable interface line cards, each featuring up to two downstream and eight upstream cable interfaces for a total of 16 downstream and 64 upstream interfaces in the chassis.

A single Cisco uBR 3x10 RF Switch is connected to the Cisco uBR10012 router, allowing you to employ a redundancy scheme in which one protect cable interface line card supports from one to seven working line cards in the same chassis. Keep in mind that like cards back up like cards (for example, a Cisco uBR10-LCP2-MC28C line card is required to back up Cisco uBR10-LCP2-MC28C line cards).



Note

An upconverter is required with this configuration.

Figure 4-1 Racked Cisco uBR 3x10 RF Switch with Cisco uBR10-LCP2-MC28C Cable Interface Line Cards and a Vecima HD4040 Upconverter

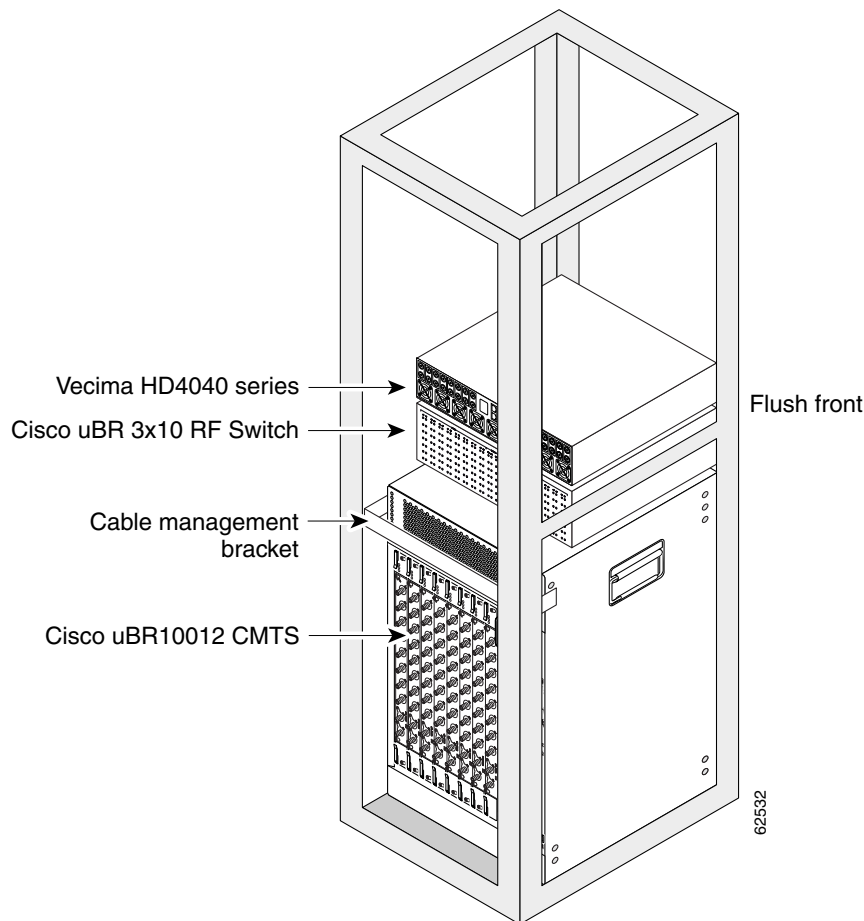

Cisco uBR 3x10 RF Switch with the Cisco uBR10-MC5X20S/U/H Cable Interface Line Cards

A single Cisco uBR10012 router supports up to eight Cisco uBR10-MC5X20S/U/H cable interface line cards, each featuring 5 downstream and 20 upstream cable interfaces for a total of 40 downstream and 160 upstream interfaces in the chassis.

For this installation, two Cisco uBR 3x10 RF Switches are required to deploy a redundancy scheme in which one protect cable interface line card supports from one to seven working cable interface line cards in the same chassis. See [Figure 4-2](#).

Note

No upconverter is required here as the Cisco uBR10-MC5X20 line cards have built in upconverters.

Figure 4-2 Racked Cisco uBR 3x10 RF Switches with Cisco uBR5X20S/U/H Cable Interface Line Cards

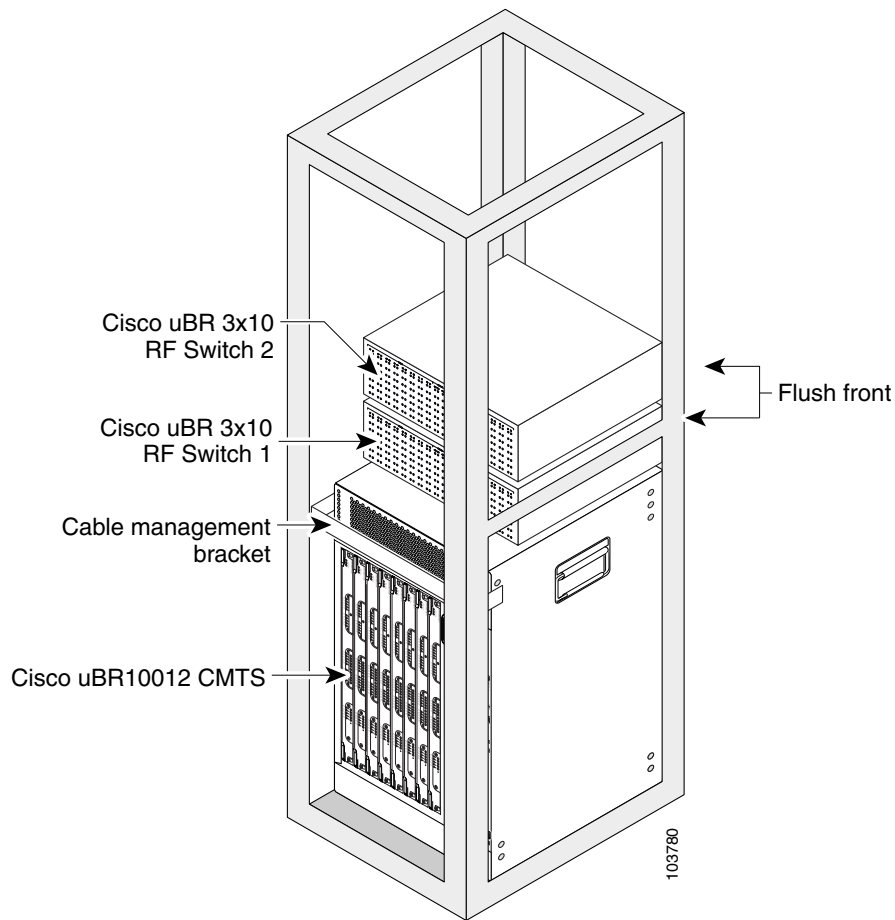

RF Cable Assemblies

The following sections describe the coaxial cables, header blocks, and F-connector assemblies required to support N+1 redundancy in networks using the RF switch when the Vecima HD4040 series IF-to-RF upconverter is used and the Cisco uBR10012 CMTSs chassis is populated with either the Cisco uBR10-LCP2-MC16x line cards or the Cisco uBR10-LCP2-MC28x.



Note

Although you may construct and implement your own cabling system according to the specifications outlined here, We recommend using the Cisco N+1 redundancy cabling solution designed specifically for this CMTS feature (Cisco part numbers CAB-RFSW-3X10-T and CAB-RFSW-3X10-10T for pre assembled, terminated cable bundles).

- Custom cables or cable components such as header blocks, crimping tools, or connectors are available from custom cable fabricators such as WhiteSands Engineering (telephone: 1 800 586 7377), or at the following URL:

<http://www.whitesandsengineering.com/>

WhiteSands Part Numbers:

Header blocks—MCXHEADERBK

MCX connectors—MCXFP (dual-shielded)

Adapters, MCX female connector to F female connector—MCXF/FF

F-connectors—ASFP (dual-shielded)

Crimper for F and MCX connectors—ACT-483

Stripper for MCXFP—CPT-7538-125 (dual-shielded)

Stripper for ASFP—CPT-7538 (dual-shielded)

Connectors for quad-shielded cables—MCXFPQ MCX

Adapters, MCX female connectors to F female connectors—MCXF/FF

Stripper for F-connectors (quad-shielded)—CPT-7538Q

Stripper for MCX connector (quad-shielded)—CPT-7538-200Q

For more information on Vecima HD4040 series IF-to-RF upconverters, go to the following URL:

<http://www.vecimanetworks.com/>

Coaxial Cables

The cables approved for use in the Cisco N+1 redundancy solution, are Mini Precision RG59 95% tinned copper braid with 100% foil shield. This cable is SDI rated with a 1 MHz to 3 GHz rating.

- CAB-RFSW-3X10-10T (bundled cable kit: 10-m, RFS to HUB, MCX to F)
- CAB-RFSW-3X10-T (bundled cable kit: 1.2-m, RFS to UPx, MCX to F)
- CAB-RFSW520TIMM (bundled cable kit: 1-m, MCX to MCX)

Figure 4-3 and Figure 4-4 on page 4-5 show header blocks that are cabled using the Cisco cable kit CAB-RFSW-3X10-10T.



Note

The header block shown in Figure 4-3 on page 4-5 is cabled for a Cisco uBR-MC16x card; the header block in Figure 4-4 on page 4-5 is cabled for the Cisco uBR-MC28x card.

Figure 4-3 Cable Solution for the Cisco uBR 3x10 RF Switch and Cisco uBR10-LCP2-MC16x Line Card

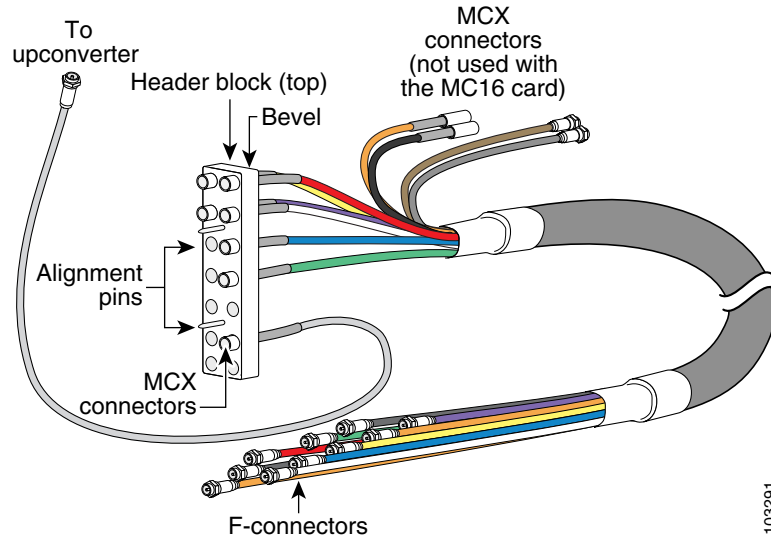
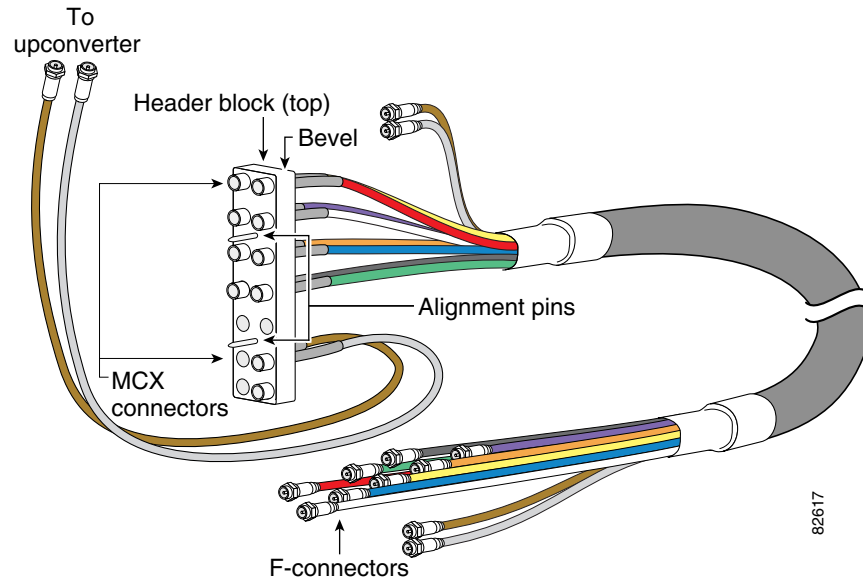

Figure 4-4 Cable Solution for the Cisco uBR 3x10 RF Switch and Cisco uBR10-LCP2-MC28x Line Card



Header Blocks

The header block holds the MCX connectors that are connected to the individual coaxial cables. These are Cisco MCX header blocks that mate to the Cisco uBR 3x10 RF Switch. Input cable kits have two extra header blocks. Output cable kits do not have header blocks.

**Note**

The header blocks are slightly beveled at the top for easy identification. The alignment pins on the header blocks are offset, preventing you from accidentally connecting the header block upside down.

F-Connectors and MCX Connectors

MCXFP—75-ohm MCX connector available from WhiteSands Engineering. This connector is attached to the end of the cable that terminates at the Cisco uBR 3x10 RF Switch.

ASFP or alternate—F-connectors available from WhiteSands Engineering. This connector is attached to the end of the cables that terminate at the upstream and downstream ports on the cable interface line cards. The output cabling kit includes 13 F-connectors to use for modification or repair.

**Note**

An extraction tool is shipped with the Cisco uBR 3x10 RF Switch to remove MCX connectors from the header blocks. Additional extraction tools can be obtained from WhiteSands Engineering.

Attenuators

A 10-dB attenuator may be required (due to a higher IF output, +42 dBmV), between the line card and the upconverter IF input ports.

RF Cable Assemblies for Cisco uBR10-MC5X20S/U/H Line Cards

The following sections describe the coaxial cable and header block assembly required to support N+1 redundancy between the Cisco uBR 3x10 RF Switches and a Cisco CMTS populated with Cisco uBR10-MC5X20S/U/H cable interface line cards.

**Note**

Although you may construct and implement your own cabling system, we recommend using the N+1 redundancy cabling solution designed specifically for this Cisco CMTS feature (Cisco part numbers CAB-RFSW520G for pre-assembled, terminated cable bundles). Pre-assembled cable sets are designed to fit the example racking configuration described in the *Rack-Mounting Cisco uBR 3x10 RF Switches with the Cisco uBR10012 CMTS and Cisco uBR10-MC5X20S/U/H Cable Interface Line Cards*. Other configurations require custom cables.

**Note**

In Europe only, the Cisco uBR10-MC5X20H card must use quad-shielded cables to connect to the RF Switch (Cisco part numbers CAB-RFSW520TIMM and CAB-RFSW520TPMF for pre-assembled, terminated cable bundles). In all other regions, the Cisco uBR10-MC5X20H card can use dual-shielded or quad-shielded cables.

The Cisco uBR10-MC5X20S and U can use dual-shielded or quad-shielded cables in all regions.

**Note**

Prepopulated custom cables for this configuration, or cable components such as header blocks, crimping tools, or connectors, are available from custom cable fabricators such as WhiteSands Engineering (1-800-JUMPERS).

Coaxial Cables

The cables approved for use in the Cisco N+1 redundancy solution, are Mini Precision RG59 95% tinned copper braid with 100% foil shield. This cable is SDI rated with a 1 MHz to 3 GHz rating.

- CAB-RFSW520TIMM (dual-shielded cable kit: 1-m cable, MC5X20S/U to RFS, two 10-bundle, one 5-bundle, and 4 headers)
- CAB-RFSW520TPMF (dual-shielded cable kit: 3-m MCX to F cable, two 10-bundle, one 5-bundle)
- CAB-RFSW520QTIMM (quad-shielded cable kit: 1-m cable, MC5X20S/U/H to RFS, five 5-bundle, and 4 headers)"
- CAB-RFSW520QTPMF (quad-shielded cable kit: 3-m MCX to F cable, five 5-bundle)

**Note**

In Europe only, the Cisco uBR10-MC5X20H card must use quad-shielded cables. In all other regions, the Cisco uBR10-MC5X20H card can use dual-shielded or quad-shielded cables.

The Cisco uBR10-MC5X20S and U can use dual-shielded or quad-shielded cables in all regions.

These coaxial cables are approved for use in the Cisco N+1 redundancy solution. The 5- and 10-cable bundle features individual coaxial cables enclosed in an external sheath. Each cable is a different color.

**Note**

The header block shown in [Figure 4-5 on page 4-8](#) is cabled for a Cisco uBR-MC5X20S/U/H card.

Figure 4-5 Cable Solution Used with the Cisco uBR10-MC5X20S/U/H Line Card

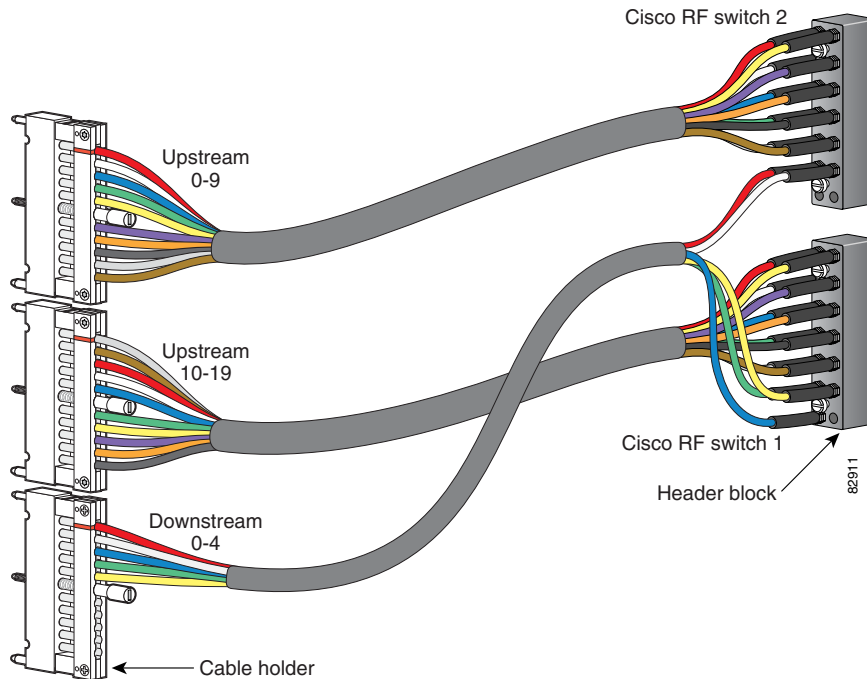

Universal Cable Holders

Universal cable holders (UCH) are used to attach the cables to the Cisco uBR10-MC5X20S/U/H cable interface line cards (see [Figure 4-5](#)). There are two types of UCH for use with these line cards: UCH1 and UCH2. (For more information, see the [Cisco uBR10-MC5X20S/U/H Cable Interface Line Card](#) document.)



Note

Universal cable holders are not included in the RF switch cable kits. The UCH are shipped with the Cisco uBR10-MC5X20S/U/H cable interface line card cable.



Caution

The Cisco uBR10-MC5X20S/U/H cable interface line card must be used with a UCH for *all* cable connections to the line card. Failure to use the UCH may cause permanent damage to the line card connectors, resulting in low or no RF output in the downstream or low or no RF input in the upstream.

Header Blocks

See the “[Header Blocks](#)” section on [page 4-5](#). An extraction tool ships with the Cisco uBR 3x10 RF Switch to remove MCX connectors from the header blocks and UCH, if necessary.

Installing the Header Blocks on the Cisco uBR 3x10 RF Switch

The RF cables are connected to the CMTS, PROTECT, and CABLE PLANT portions of the RF switch using the header blocks. Header blocks are installed on the RF switch at the following locations:

- CMTS—RF cables connect to working cable interface line cards and to IF-to-RF upconverters.
- PROTECT—RF cables connect to protecting cable interface line cards
- CABLE PLANT—RF cables connect to the cable headend or hub.

Equipment

- 18 header blocks—one RF switch
- 34 header blocks—two RF switches
- Flat-blade screwdriver

To install the header blocks, complete the following steps:

-
- Step 1** With the beveled edge of the header block at the top, align the two alignment pins on the header block with the two alignment holes on the RF switch (CMTS, PROTECT, or CABLE PLANT section).
- Step 2** Press the header block into place, using equal pressure on both the upper and lower portions of the header block.
- Step 3** Use a flat-blade screwdriver to tighten the captive installation screws at both the top and bottom of the header block to prevent accidental disconnections.



Note Tighten the header blocks to the Cisco uBR 3x10 RF Switch only after installing and gently pulling on the cables to be sure that they are firmly seated in the header block.



Caution

Do not overtighten. We recommend tightening to 5 to 7 inch-pounds (0.5649 to 0.7909 Nm).

Figure 4-6 Header Block Description

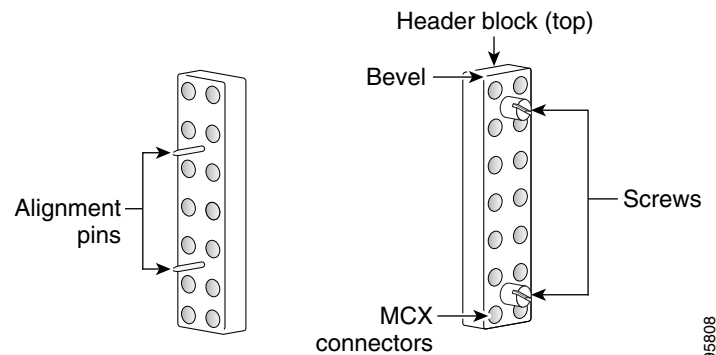

Mapping the RF Cables from the Working and Protect Line Cards (MC16x, MC28C) to the Cisco uBR 3x10 RF Switch

This section provides guidelines for mapping the RF cables and contains the following subsections:

- [Mapping the Cisco uBR10-LCP2-MC28C Cable Interface Line Cards to the RF Switch, page 4-13](#)
- [Mapping the Cisco uBR10-LCP2-MC16x \(C,E,S\) Cable Interface Line Cards to the RF Switch, page 4-11](#)



Note

This sample mapping (or any other valid mapping method) is applicable to both working and protect cable interface line cards when employing N+1 redundancy.

Figure 4-7 Cable Interface Line Card Slot Numbers (Cisco uBR10-LCP2-MC28C Line Card Shown)

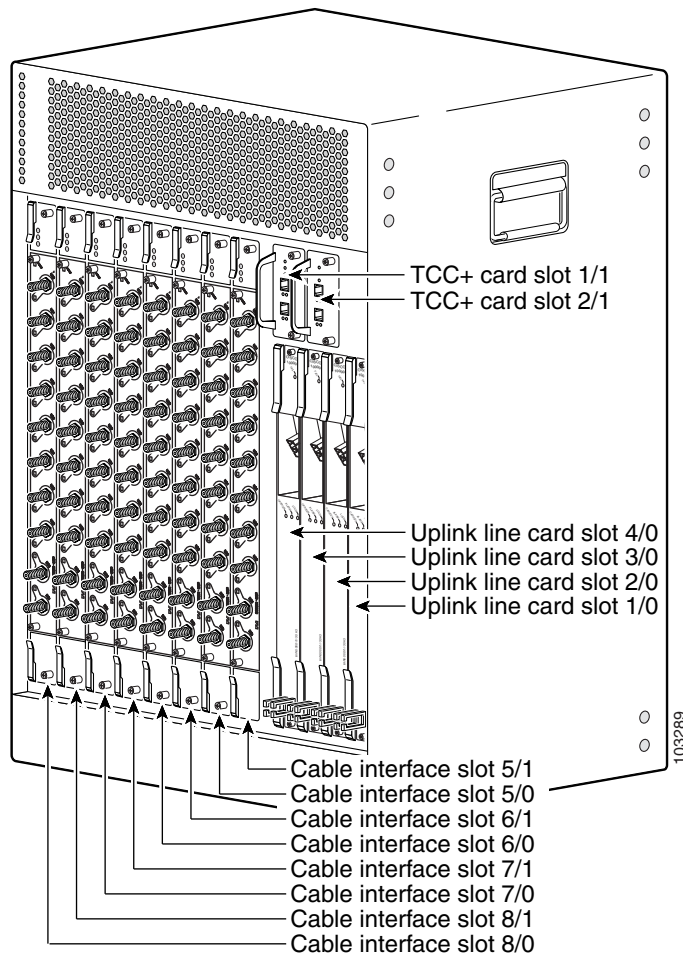

Mapping the Cisco uBR10-LCP2-MC16x(C,E,S) Cable Interface Line Cards to the RF Switch

The following guidelines can help you map the RF cables between the Cisco uBR 3x10 RF Switch and the Cisco uBR10-LCP2-MC16x cable interface line cards in the Cisco uBR10012 router:

- The RF switch ports labeled A to E and H to L on the header block connect to the upstream ports on the Cisco uBR10-LCP2-MC16C, MC16E, or MC16S cable interface line cards installed in the Cisco uBR10012 CMTS.
- The RF switch ports labeled F are used only for the downstream port connections.
 - The DS0 port on Cisco uBR10-LCP2-MC16x (C, E, S) line card is cabled first to the upconverter and then from the upconverter to the RF switch. A 10-dB attenuator may be required (due to a higher IF output) between the line cards and the upconverter.
- The MCX connection labeled N on the header block does not connect to anything in the RF switch and should not be connected to any cable interface port either.



Note

We recommend that the protect card be installed in slot 5/1 because this slot is directly below the PROTECT section on the RF switch.

Table 4-1 provides one permutation of the connection between a header block attached to a Cisco uBR 3x10 RF Switch and the cable interface ports on a Cisco uBR10-LCP2-MC16x line card installed in a Cisco uBR10012 CMTS.

Table 4-1 Sample Mapping of a Cisco uBR10-LCP2-MC16x Cable Interface Line Card to the Cisco uBR 3x10 RF Switch

Connect to the Cable Interface on the CMTS	RFS ¹ (Color)	RFS (Color)	Connect to the Cable Interface on the CMTS
US0	A (Red)	H (Yellow)	US4
US1	B (White)	I (Violet)	US5
US2	C (Blue)	J	(Unused upstream)
US3	D (Green)	K	(Unused upstream)
(Unused upstream)	E	L	(Unused upstream)
DS0	F (Gray)	M	(Unused downstream)
(Unused downstream)	G	N	(Not connected)

1. RFS—RF switch, location of the MCX connection on the RF switch.



Note

This sample mapping (or any other valid mapping method) is applicable to both working and protect cable interface line cards when employing N+1 redundancy. The distinction between which line card serves as the protect card and which ones serve as the working cards is decided by whether the header block is plugged into a working (switch side) or protect group of interfaces on the RF switch and by the configuration you specify using the information in the “N+1 Redundancy for the Cisco CMTS” chapter of the *Cisco Cable Modem Termination System Feature Guide*.

Figure 4-8 Mapping a Cisco uBR10012 CMTS Populated with Cisco uBR10-LCP2-MC16x Line Cards to the RF Switch

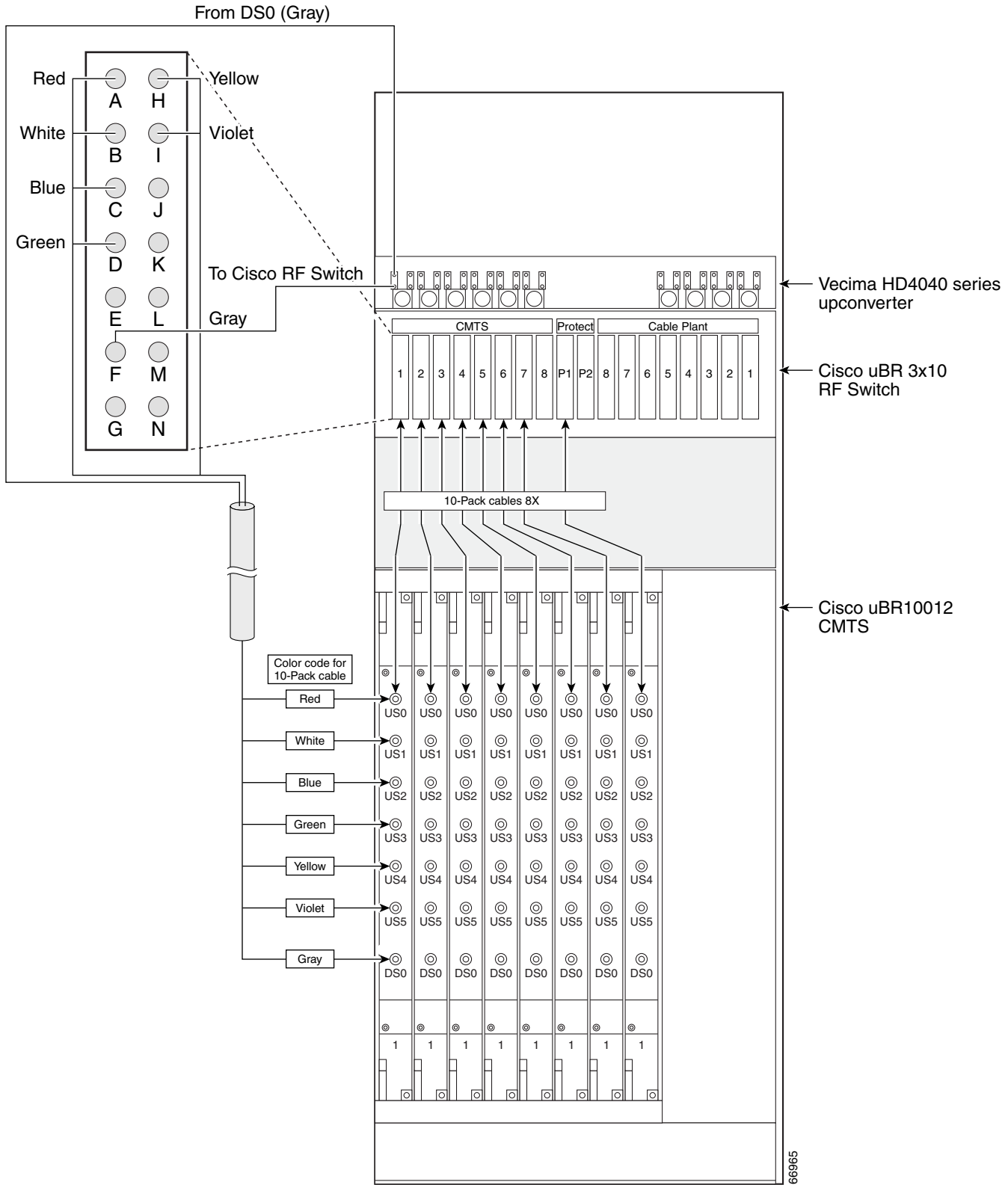

Mapping the Cisco uBR10-LCP2-MC28C Cable Interface Line Cards to the RF Switch

When you connect RF cables between the RF switch and a Cisco uBR10-LCP2-MC28C cable interface line card installed in a Cisco uBR10012 router, ensure that all the RF cables in the bundle attach to interfaces on the same cable interface line card installed in the Cisco uBR10012 chassis. (See [Figure 4-9 on page 4-14](#).)

The following guidelines can help you map the cables between the RF switch and the Cisco uBR10012:

- The cable interface ports labeled A to E and H to L on the header blocks are used for the upstream port connections on the Cisco uBR10-LCP2-MC28C line card installed in the Cisco uBR10012 CMTS.
- The cable interface ports labeled F, G, and M are used only for the downstream port connections.
 - The DS0 and DS1 ports on Cisco uBR10-LCP2-MC28C are cabled first to the upconverter and then from the upconverter to the RF switch. A 10-dB attenuator may be required between the line card and the upconverter., due to a higher IF output.
- The cable interface port labeled N on the header block does not connect to anything in the Cisco uBR 3x10 RF Switch and should not be connected to any cable interface port either.



Note

We recommend that the protect card be installed in slot 5/1 because this slot is directly below the PROTECT section on the RF switch.

[Table 4-2](#) provides one permutation of the connection between a header block attached to a Cisco uBR 3x10 RF Switch and the cable interfaces on a Cisco uBR10-LCP2-MC28x installed in a Cisco uBR10012 CMTS.



Tip

Notice the relationship between the cable color and location in the RF switch.

Table 4-2 Sample Mapping of a Cisco uBR-MC28C Line Card to the Cisco uBR 3x10 RF Switch

Connect to the Cable Interface on the CMTS	RFS ¹ (Color)	RFS (Color)	Connect to the Cable Interface on the CMTS
US0 of first MAC domain	A (Red)	H (Yellow)	US0 of second MAC domain
US1 of first MAC domain	B (White)	I (Violet)	US1 of second MAC domain
US2 of first MAC domain	C (Blue)	J (Orange)	US2 of second MAC domain
US3 of first MAC domain	D (Green)	K (Black)	US3 of second MAC domain
(Unused upstream)	E	L	(Unused upstream)
DS0	F (Gray)	M (Brown)	DS1
(Unused downstream)	G	N	(Not connected)

1. RFS—RF switch, location of the MCX connection on the RF switch.

Figure 4-9 Mapping a Cisco uBR10012 CMTS Populated with Cisco-uBR10-LCP2-MC28C Line Cards to the RF Switch

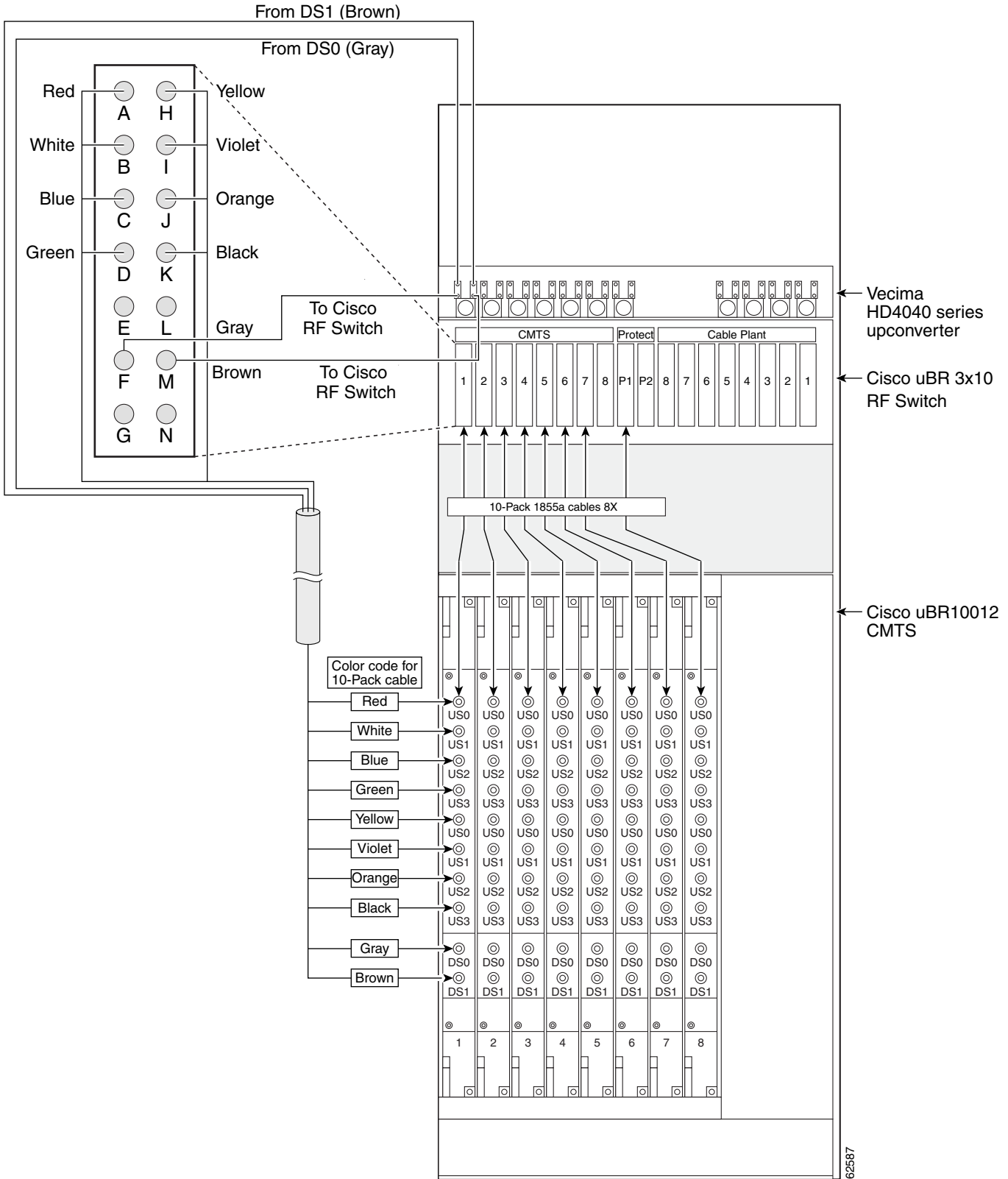

62587

Connecting the RF Cables (MC16x, MC28C Line Cards)

The RF cables are connected between the Cisco uBR10-LCP2-MC16x (C, E, S) line cards or the Cisco uBR10-LCP2-MC28C line cards, and the CMTS and PROTECT portions of the Cisco uBR 3x10 RF Switch in bundles of RF cables. The cables terminate at header blocks that connect to the RF switch at one of the following locations:

- CMTS—These groups of RF cables connect to cable interface line cards designated as the working line cards and to IF-to-RF upconverters.
- PROTECT—These groups of RF cables connect to cable interface line cards designated as the protect line cards.

For information about cabling to the Vecima HD4040 upconverter, refer to the [“Cabling the Output Ports from the Upconverter to the RF Switch”](#) section on page 4-18.

**Note**

CABLE PLANT connections are made after all the other connections have been made. The CABLE PLANT RF cables connect to the coaxial or fiber-optic cable transceivers (in the upstream direction) and IF-to-RF upconverters (in the downstream direction) at the cable headend or hub.

For cable mapping information, refer to:

- [“Mapping the Cisco uBR10-LCP2-MC28C Cable Interface Line Cards to the RF Switch”](#) section on page 4-13.
- [“Mapping the Cisco uBR10-LCP2-MC16x \(C,E,S\) Cable Interface Line Cards to the RF Switch”](#) section on page 4-11.

Cabling the Working and Protect Line Cards to the RF Switch

This section describes cabling the working and protect line cards from the Cisco uBR10012 CMTS to the RF switch.

**Tip**

Use the card in slot 5/1 for the protect card. See [Figure 4-7 on page 4-10](#) for slot number locations.

Equipment

- 8–RF cable bundles (CAB-RFSW-3X10-T)
- 8–header blocks (installed)
- Flat-blade screwdriver (extended length)

To cable the card, complete the following steps.

Step 1 Connect the cables to the cable interface line card connectors (upstream and downstream).

**Note**

We recommend that you tighten the F-connectors to a value between 10 (recommended) and 15 (maximum) inch-pounds (1.1298 and 1.7339 Nm).

Step 2 Run the cable bundle (behind the cable management bracket if it was installed) up to the CMTS header blocks on the RF switch.



Tip See [Table 4-2 on page 4-13](#) and [Table 4-1 on page 4-11](#) for cable interface and CMTS connection locations. Note that the gray and brown cables have F-connectors instead of MCX connectors. These cables are used to connect to the upconverter (UPx).

- Step 3** Install the cables in the CMTS header block in the order that they were mapped.
 - a. Push the MCX connector into the hole in the header block until you can feel it snap into place.
 - b. Gently wiggle the connector to make sure that the connection is secure.
- Step 4** Repeat [Step 1](#) through [Step 3](#) for the other line cards.
- Step 5** Repeat [Step 1](#) through [Step 3](#) for the PROTECT (P1A–P1H) header block.
- Step 6** Gently pull on the cables to be sure that they are firmly seated in the header blocks.



Caution To ensure proper installation and avoid poor connections, be sure that the cables are not positioned at too acute an angle.

- Step 7** Use a flat-blade screwdriver to tighten the captive installation screws at both the top and the bottom of the header block to prevent accidental disconnection.



Caution Do not overtighten the captive screws. We recommend that you tighten the screws to 5 to 7 inch-pounds (0.5647 to 0.7909 Nm).

Figure 4-10 Cisco uBR 3x10 RF Switch—MCX Connection Locations

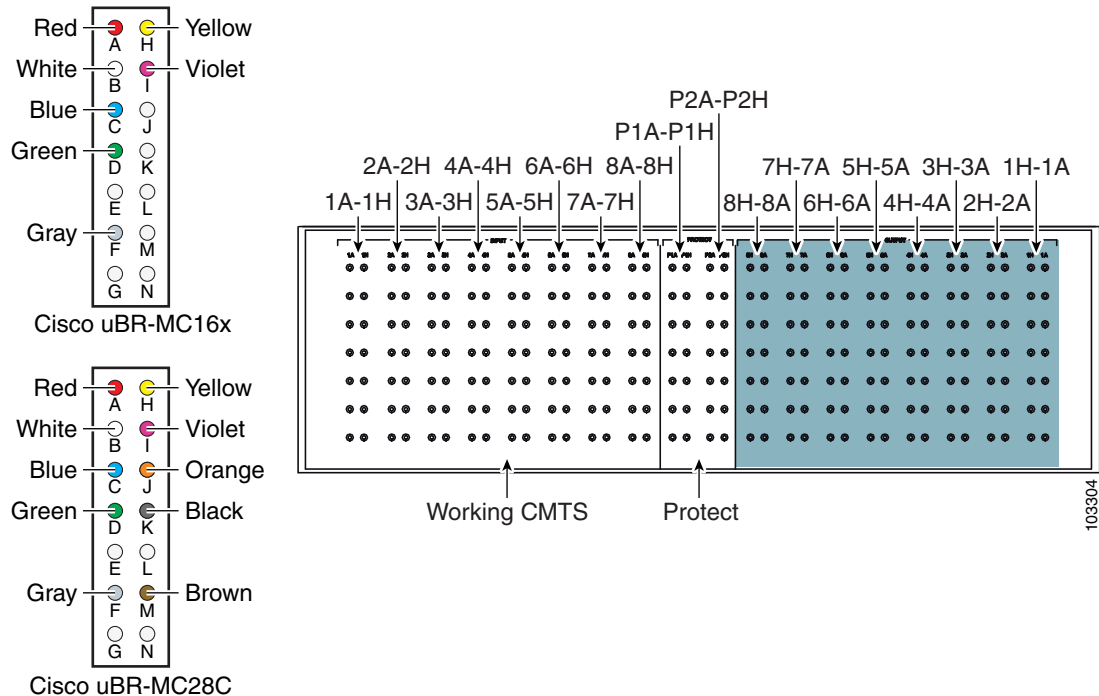

Cabling the Downstream Ports to the Input Ports on the Upconverter

This section describes cabling the Cisco uBR10-LCP2-MC16x and Cisco uBR10-LCP2-MC28C line card downstream (DS) ports to the upconverter.

Equipment

These cables are part of the cable bundles (CAB-RFSW-3X10-T).



Tip Alternate gray and brown cables when cabling the Cisco uBR10-LCP2-MC28C card.

To cable the downstream ports to the upconverter, complete the following steps.

- Step 1** Connect the cables to the downstream ports (MC16x–DS0, MC28C–DS0, DS1) on the line cards.
- Step 2** Run the cables up to the upconverter and add a 10-dB attenuator to the input cable, if necessary.
- Step 3** Connect the cables to the input ports (top) on the upconverter.
- See [Table 4-3](#) and [Figure 4-11](#) on page 4-17 when cabling a Cisco uBR10-LCP2-MC16x line card.
 - See [Table 4-4](#) and [Figure 4-12](#) on page 4-18 when cabling a Cisco uBR10-LCP2-MC28C line card.

Figure 4-11 Cabling the Upconverter (MC16x)

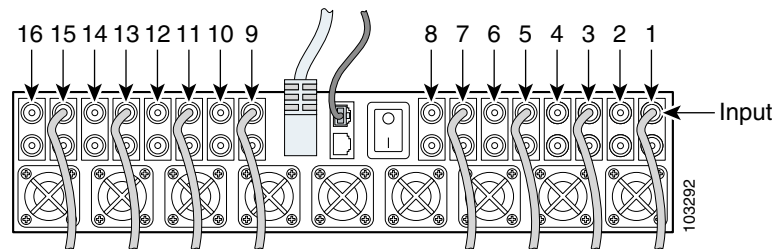

Table 4-3 Cisco uBR10-LCP2-MC16x Cabling (DS Ports to the Upconverter)

Color	Line Card Slot	UPx Conn.	✓	Color	Line Card Slot	UPx Conn.	✓
Gray	8/0—working	15		Gray	6/0—working	7	
Gray	8/1—working	13		Gray	6/1—working	5	
Gray	7/0—working	11		Gray	5/0—working	3	
Gray	7/1—working	9		Gray	5/1—protect	1	

Figure 4-12 Cabling the Input Ports on the Upconverter (MC28C)

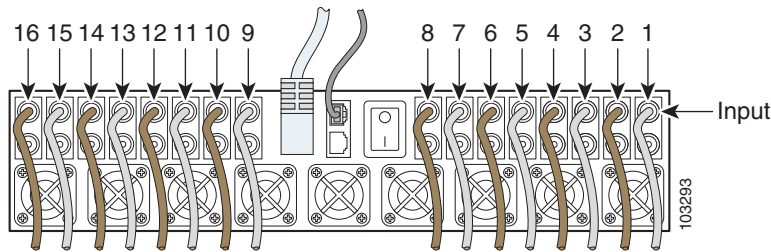

Table 4-4 Cisco uBR10-LCP2-MC28C Cabling (DS Ports to the Upconverter)

Color	Line Card Slot	DS Port	UPx Conn	✓	Color	Line Card Slot	DS Port	UPx Conn	✓
Brown	8/0—working	DS1	16		Brown	6/0—working	DS1	8	
Gray	8/0—working	DS0	15		Gray	6/0—working	DS0	7	
Brown	8/1—working	DS1	14		Brown	6/1—working	DS1	6	
Gray	8/1—working	DS0	13		Gray	6/1—working	DS0	5	
Brown	7/0—working	DS1	12		Brown	5/0—working	DS1	4	
Gray	7/0—working	DS0	11		Gray	5/0—working	DS0	3	
Brown	7/1—working	DS1	10		Brown	5/1—protect	DS1	2	
Gray	7/1—working	DS0	9		Gray	5/1—protect	DS0	1	

Cabling the Output Ports from the Upconverter to the RF Switch

This section describes cabling from the output ports on the upconverter to the RF switch.

Equipment

- 8 cables for Cisco uBR10-LCP2-MC16x cards (F-connector to MCX connector—gray)
- 16 cables for Cisco uBR10-LCP2-MC28C cards (F-connector to MCX connector—gray, brown)

To cable the output ports on the upconverter to the RF switch, complete the following steps.

-
- Step 1** Connect the cable to the output connector (1—lower) on the upconverter.
- Step 2** Connect the cable to the appropriate MCX connection on the CABLE PLANT header block.
- For Cisco uBR10-LCP2-MC16x cards, see [Table 4-5 on page 4-19](#).
 - For Cisco uBR10-LCP2-MC28C cards, see [Table 4-6 on page 4-19](#).
- Step 3** Repeat [Step 1](#) through [Step 2](#) for the remaining cables
-

Table 4-5 Upconverter Output Cables to the Working Plant on the RF Switch (for MC16x Line Cards)

Color	UPx Output	RFS-CMTS	LC Slot (DS)	✓
Gray	15	1F—cable plant	8/0—working (DS)	
Gray	13	2F—cable plant	8/1—working (DS)	
Gray	11	3F—cable plant	7/0—working (DS)	
Gray	9	4F—cable plant	7/1—working (DS)	
Gray	7	5F—cable plant	6/0—working (DS)	
Gray	5	6F—cable plant	6/1—working (DS)	
Gray	3	7F—cable plant	5/0—working (DS)	
Gray	1	1P F—protect (1P)	5/1—protect (DS)	

Table 4-6 Upconverter Output Cables to the Working Plant on the RF Switch (for MC28C Line Cards)

Color	UPx Output	RFS CMTS	LC Slot (DS)	✓		Color	UPx Output	RFS CMTS	LC Slot (DS)	✓
Brown	16	1M	8/0—working(DS1)			Brown	8	5M	6/0—working (DS1)	
Gray	15	1F	8/0—working(DS0)			Gray	7	5F	6/0—working (DS0)	
Brown	14	2M	8/1—working(DS1)			Brown	6	6M	6/1—working (DS1)	
Gray	13	2F	8/1—working(DS0)			Gray	5	6F	6/1—working (DS0)	
Brown	12	3M	7/0—working(DS1)			Brown	4	7M	5/0—working (DS1)	
Gray	11	3F	7/0—working(DS0)			Gray	3	7F	5/0—working (DS0)	
Brown	10	4M	7/1—working(DS1)			Brown	2	1PM	5/1—protect (DS1)	
Gray	9	4F	7/1—working(DS0)			Gray	1	1PF	5/1—protect (DS0)	

Cabling the Output Cables (CABLE PLANT to HUB)

This section describes cabling the RF switch for output (from the RF switch CABLE PLANT to the cable headend equipment).

The output cables are connected to the CABLE PLANT section of the RF switch. The CABLE PLANT header blocks are wired in the opposite sequence to the CMTS and PROTECT header blocks (see [Figure 4-14 on page 4-21](#)). Use the same installation and connection procedures as described in these sections:

- [Installing the Header Blocks on the Cisco uBR 3x10 RF Switch, page 4-9](#)
- [Connecting the RF Cables \(MC16x, MC28C Line Cards\), page 4-15](#)

Equipment

- 7 cable bundles (10m), MCX connector to F-connector—multicolor, CAB-RFSW-3X10-10T
- 14 single cables
- 7 header blocks (installed)



Tip

For shorter cables (3m) use cable kit CAB-RFSW520TPMF (dual-shielded) or CAB-RFSW520QTPMF (quad-shielded).

To cable the output connections, complete the following steps.

- Step 1** Install the header blocks on the CABLE PLANT section of the RF switch. Refer to [Installing the Header Blocks on the Cisco uBR 3x10 RF Switch](#), page 4-9, if necessary.
- Step 2** Install the output cables in the header blocks. Refer to [Mapping the Cisco uBR10-LCP2-MC28C Cable Interface Line Cards to the RF Switch](#), page 4-13 for RF switch/MCX connector installation instructions, if necessary.
- Step 3** Run the output cables (H–A) from header blocks to splitters, US laser receivers, or the low side of the diplex filters
- Step 4** Run the output cables (F) or (M–F) to the splitters/combiners, DS laser transmitters, or the high side of the diplex filters.

Figure 4-13 RF Switch Cable Plant Outputs (Turquoise)

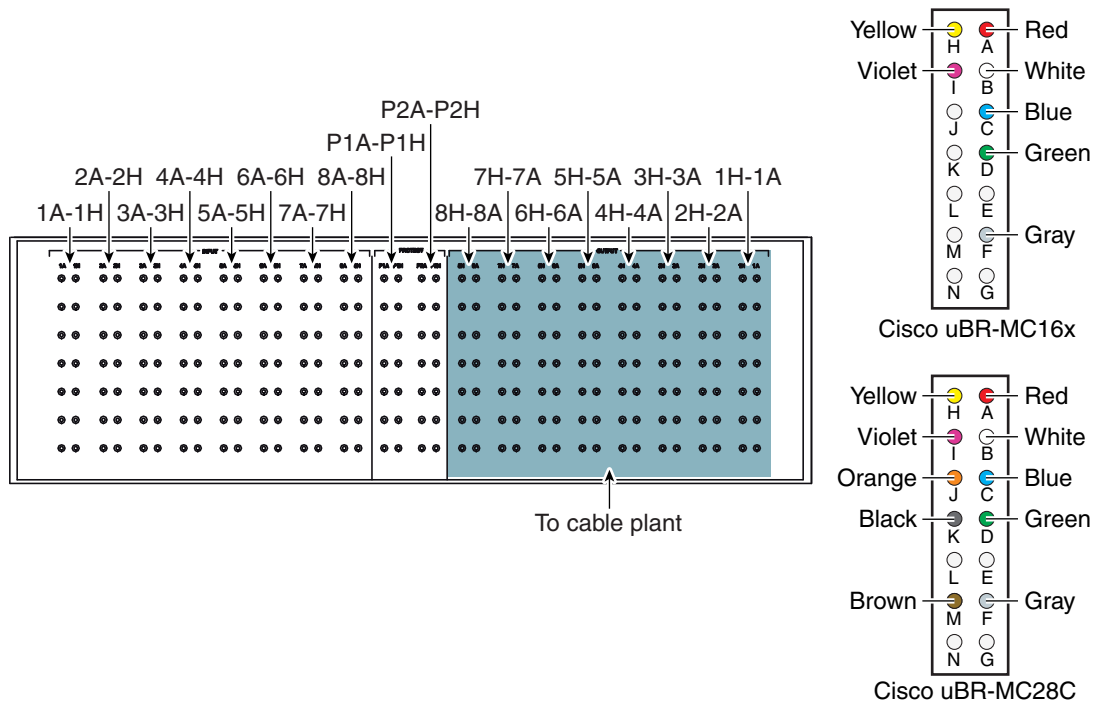

103305

Mapping the Working and Protect Cisco uBR10-MC5X20S/U/H Line Cards RF Cables to the RF Switch

This section describes the mapping of RF cables from the working and protect line cards to the Cisco uBR 3x10 RF Switch. Refer to [Figure 4-14](#) for header block and cable designations as viewed from the cable side of the header blocks.

When you connect RF cables between the RF switch and a cable interface line card installed in a Cisco uBR10012 chassis, ensure that all the RF cables in the bundle attach to interfaces on the same cable interface line card installed in the Cisco uBR10012 chassis. (Refer to [Table 4-7](#), [Table 4-8](#), [Table 4-9](#), and [Table 4-10](#) for line card-to-RF switch port mapping information.)

Figure 4-14 Wiring the CMTS and Protect Headers (Cable Plant Headers Shown for Comparison)

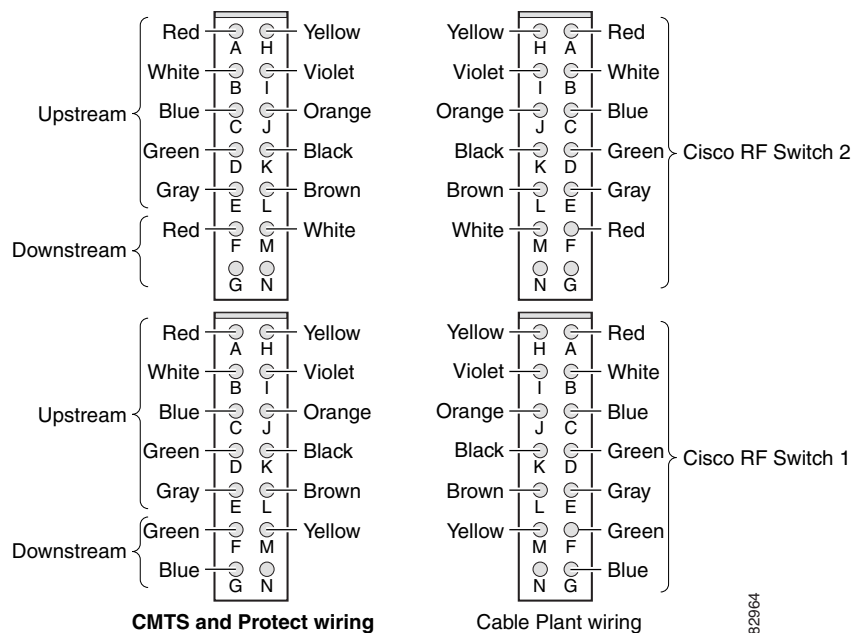

Use the following guidelines to map cables between the Cisco uBR 3x10 RF Switch and the Cisco uBR10012 CMTS:

- The cable interface ports labeled A through E and H through L on the header block all must attach to upstream interfaces on the Cisco uBR10012 chassis.
- The cable interface ports labeled F, G, and M are applicable only to downstream connection.
- The cable interface port labeled N on the header block does not attach to anything in the RF switch. Therefore, it should not be connected to any cable interface on the Cisco uBR10012 CMTS.



Note

This mapping is applicable to both working and protect cable interface line cards when employing N+1 redundancy. The distinction between which cable interface line card serves as a protect line card and which serve as working line cards is determined by whether the header block is plugged into a working (switch side) or protect group of slots on the Cisco uBR 3x10 RF Switch and by the configuration you specify. Refer to the “N+1 Redundancy for the Cisco CMTS” chapter of the *Cisco Cable Modem Termination System Feature Guide*.

Table 4-7 RF Switch Ports and Line Card Ports for Line Card Slots 8/0 and 8/1

Cable Color	Working Line Card Slot 8/0—Ports	RF Switch—Port		Working Line Card Slot 8/1—Ports	RF Switch—Port	
Red	US0	RFS-2-1A		US0	RFS-2-2A	
White	US1	RFS-2-1B		US1	RFS-2-2B	
Blue	US2	RFS-2-1C		US2	RFS-2-2C	
Green	US3	RFS-2-1D		US3	RFS-2-2D	
Yellow	US4	RFS-2-1H		US4	RFS-2-2H	
Violet	US5	RFS-2-1I		US5	RFS-2-2I	
Orange	US6	RFS-2-1J		US6	RFS-2-2J	
Black	US7	RFS-2-1K		US7	RFS-2-2K	
Gray	US8	RFS-2-1E		US8	RFS-2-2E	
Brown	US9	RFS-2-1L		US9	RFS-2-2L	
Gray	US10	RFS-1-1E		US10	RFS-1-2E	
Brown	US11	RFS-1-1L		US11	RFS-1-2L	
Red	US12	RFS-1-1A		US12	RFS-1-2A	
White	US13	RFS-1-1B		US13	RFS-1-2B	
Blue	US14	RFS-1-1C		US14	RFS-1-2C	
Green	US15	RFS-1-1D		US15	RFS-1-2D	
Yellow	US16	RFS-1-1H		US16	RFS-1-2H	
Violet	US17	RFS-1-1I		US17	RFS-1-2I	
Orange	US18	RFS-1-1J		US18	RFS-1-2J	
Black	US19	RFS-1-1K		US19	RFS-1-2K	
Red	DS0	RFS-2-1F		DS0	RFS-2-2F	
White	DS1	RFS-2-1M		DS1	RFS-2-2M	
Blue	DS2	RFS-1-1G		DS2	RFS-1-2G	
Green	DS3	RFS-1-1F		DS3	RFS-1-2F	
Yellow	DS4	RFS-1-1M		DS4	RFS-1-2M	

Table 4-8 RF Switch Ports and Line Card Ports for Line Card Slots 7/0 and 7/1

Cable Color	Working Line Card Slot 7/0—Ports	RF Switch—Port	✓	Working Line Card Slot 7/1—Ports	RF Switch—Port	✓
Red	US0	RFS-2-3A		US0	RFS-2-4A	
White	US1	RFS-2-3B		US1	RFS-2-4B	
Blue	US2	RFS-2-3C		US2	RFS-2-4C	
Green	US3	RFS-2-3D		US3	RFS-2-4D	
Yellow	US4	RFS-2-3H		US4	RFS-2-4H	
Violet	US5	RFS-2-3I		US5	RFS-2-4I	
Orange	US6	RFS-2-3J		US6	RFS-2-4J	
Black	US7	RFS-2-3K		US7	RFS-2-4K	
Gray	US8	RFS-2-3E		US8	RFS-2-4E	
Brown	US9	RFS-2-3L		US9	RFS-2-4L	
Gray	US10	RFS-1-3E		US10	RFS-1-4E	
Brown	US11	RFS-1-3L		US11	RFS-1-4L	
Red	US12	RFS-1-3A		US12	RFS-1-4A	
White	US13	RFS-1-3B		US13	RFS-1-4B	
Blue	US14	RFS-1-3C		US14	RFS-1-4C	
Green	US15	RFS-1-3D		US15	RFS-1-4D	
Yellow	US16	RFS-1-3H		US16	RFS-1-4H	
Violet	US17	RFS-1-3I		US17	RFS-1-4I	
Orange	US18	RFS-1-3J		US18	RFS-1-4J	
Black	US19	RFS-1-3K		US19	RFS-1-4K	
Red	DS0	RFS-2-3F		DS0	RFS-2-4F	
White	DS1	RFS-2-3M		DS1	RFS-2-4M	
Blue	DS2	RFS-1-3G		DS2	RFS-1-4G	
Green	DS3	RFS-1-3F		DS3	RFS-1-4F	
Yellow	DS4	RFS-1-3M		DS4	RFS-1-4M	

Table 4-9 RF Switch Ports and Line Card Ports for Line Card Slots 6/0 and 6/1

Cable Color	Working Line Card Slot 6/0—Ports	RF Switch—Port	✓	Working Line Card Slot 6/1—Ports	RF Switch—Port	✓
Red	US0	RFS-2-5A		US0	RFS-2-6A	
White	US1	RFS-2-5B		US1	RFS-2-6B	
Blue	US2	RFS-2-5C		US2	RFS-2-6C	
Green	US3	RFS-2-5D		US3	RFS-2-6D	
Yellow	US4	RFS-2-5H		US4	RFS-2-6H	
Violet	US5	RFS-2-5I		US5	RFS-2-6I	
Orange	US6	RFS-2-5J		US6	RFS-2-6J	
Black	US7	RFS-2-5K		US7	RFS-2-6K	
Gray	US8	RFS-2-5E		US8	RFS-2-6E	
Brown	US9	RFS-2-5L		US9	RFS-2-6L	
Gray	US10	RFS-1-5E		US10	RFS-1-6E	
Brown	US11	RFS-1-5L		US11	RFS-1-6L	
Red	US12	RFS-1-5A		US12	RFS-1-6A	
White	US13	RFS-1-5B		US13	RFS-1-6B	
Blue	US14	RFS-1-5C		US14	RFS-1-6C	
Green	US15	RFS-1-5D		US15	RFS-1-6D	
Yellow	US16	RFS-1-5H		US16	RFS-1-6H	
Violet	US17	RFS-1-5I		US17	RFS-1-6I	
Orange	US18	RFS-1-5J		US18	RFS-1-6J	
Black	US19	RFS-1-5K		US19	RFS-1-6K	
Red	DS0	RFS-2-5F		DS0	RFS-2-6F	
White	DS1	RFS-2-5M		DS1	RFS-2-6M	
Blue	DS2	RFS-1-5G		DS2	RFS-1-6G	
Green	DS3	RFS-1-5F		DS3	RFS-1-6F	
Yellow	DS4	RFS-1-5M		DS4	RFS-1-6M	

Table 4-10 RF Switch Ports and Line Card Ports for Line Card Slots 5/0 and 5/1

Cable Color	Working Line Card Slot 5/0—Ports	RF Switch—Port	✓	Protect Line Card Slot 5/1—Ports	RF Switch—Port	✓
Red	US0	RFS-2-7A		US0	RFS-2-P1A	
White	US1	RFS-2-7B		US1	RFS-2-P1B	
Blue	US2	RFS-2-7C		US2	RFS-2-P1C	
Green	US3	RFS-2-7D		US3	RFS-2-P1D	
Yellow	US4	RFS-2-7H		US4	RFS-2-P1H	
Violet	US5	RFS-2-7I		US5	RFS-2-P1I	
Orange	US6	RFS-2-7J		US6	RFS-2-P1J	
Black	US7	RFS-2-7K		US7	RFS-2-P1K	
Gray	US8	RFS-2-7E		US8	RFS-2-P1E	
Brown	US9	RFS-2-7L		US9	RFS-2-P1L	
Gray	US10	RFS-1-7E		US10	RFS-1-P1E	
Brown	US11	RFS-1-7L		US11	RFS-1-P1L	
Red	US12	RFS-1-7A		US12	RFS-1-P1A	
White	US13	RFS-1-7B		US13	RFS-1-P1B	
Blue	US14	RFS-1-7C		US14	RFS-1-P1C	
Green	US15	RFS-1-7D		US15	RFS-1-P1D	
Yellow	US16	RFS-1-7H		US16	RFS-1-P1H	
Violet	US17	RFS-1-7I		US17	RFS-1-P1I	
Orange	US18	RFS-1-7J		US18	RFS-1-P1J	
Black	US19	RFS-1-7K		US19	RFS-1-P1K	
Red	DS0	RFS-2-7F		DS0	RFS-2-P1F	
White	DS1	RFS-2-7M		DS1	RFS-2-P1M	
Blue	DS2	RFS-1-7G		DS2	RFS-1-P1G	
Green	DS3	RFS-1-7F		DS3	RFS-1-P1F	
Yellow	DS4	RFS-1-7M		DS4	RFS-1-P1M	

Connecting the RF Cables (Cisco uBR10-MC5X20S/U/H)

This section describes connecting the Cisco uBR-MC5X20S/U/H cable interface line card to the RF switch. RF cable bundles are used to connect the Cisco uBR-MC5X20S/U/H cable interface line card to the CMTS, PROTECT, and CABLE PLANT portions of the Cisco uBR 3x10 RF Switches (RFS).

- CMTS—cabled to the designated working line cards.
- PROTECT—cabled to the designated protect line card.
- CABLE PLANT—cabled to the coaxial or fiber-optic transceivers at the cable headend or hub.



Note

Two Cisco uBR 3x10 RF Switches are required for this configuration, see [Figure 4-2 on page 4-3](#).

Equipment

- 8 RF cable kits:
CAB-RFSW520TIMM (MC5X20S/U to RFS, dual-shielded, two 10-bundle, one 5-bundle)
or
CAB-RFSW520QTIMM (MC5X20S/U/H to RFS, quad-shielded, five 5-bundle)
- 34 header blocks (for the CMTS, PROTECT, CABLE PLANT sections on the RF switch)
- Flat-blade screwdriver



Note

You can use any combination of dual- and quad-shielded cables, depending on personal preference and which MC5X20 boards you have installed.

In Europe only, the Cisco uBR10-MC5X20H card must use quad-shielded cables. In all other regions, the Cisco uBR10-MC5X20H card can use dual-shielded or quad-shielded cables.

The Cisco uBR10-MC5X20S and U can use dual-shielded or quad-shielded cables in all regions.

This procedure assumes that the RF cables are already installed in the universal cable holder (UCH) and mounted on the Cisco uBR-MC5X20S/U/H cable interface line card. If the cables have not been installed in the UCH and mounted on the line card, refer to the *Cisco uBR-MC5X20S/U/H Cable Interface Line Card* documentation at the following URL:

<http://www.cisco.com/univercd/cc/td/doc/product/cable/ubr10k/ubr10012/frus/ubrmc520.htm>

To connect the header blocks and install the cables on the RF switch, complete the following steps:

-
- Step 1** Install the header blocks on the Cisco uBR 3x10 RF Switches.
- With the beveled edge of the header block at the top, line up the two alignment pins on the header block with the two holes corresponding to the RF connector group (CMTS, PROTECT, or CABLE PLANT) on the RF switch. See [Figure 4-15 on page 4-27](#).
 - Press the header block into place, using equal pressure on both the upper and lower portions of the header block.
- Step 2** Run the cables (behind the cable management bracket if it is installed) up to the CMTS header blocks on the RF switch.
- Step 3** Insert the MCX connectors into the header blocks according to the mapping in the “[Mapping the Working and Protect Cisco uBR10-MC5X20S/U/H Line Cards RF Cables to the RF Switch](#)” section on [page 4-21](#).

For cabling locations, refer to:

- [Table 4-7 on page 4-22](#) for slot 8/0 and 8/1 working line card RF switch connections.
- [Table 4-8 on page 4-23](#) for slot 7/0 and 7/1 working line card RF switch connections.
- [Table 4-9 on page 4-24](#) for slot 6/0 and 6/1 working line card RF switch connections.
- [Table 4-10 on page 4-25](#) for slot 5/0 and 5/1 working and protect line card RF switch connections.

Step 4 Gently pull on the cables to be sure that they are firmly seated in the header blocks.

Step 5 Use a flat-blade screwdriver to tighten the captive installation screws at both the top and bottom of the header block to prevent accidental disconnections.



Caution

Do not over-tighten the captive screws. We recommend that you tighten the captive screws to 5 to 7 inch-pounds (0.5647 to 0.7909 Nm).

Figure 4-15 Cisco uBR 3x10 RF Switch Header Block with Cables Installed

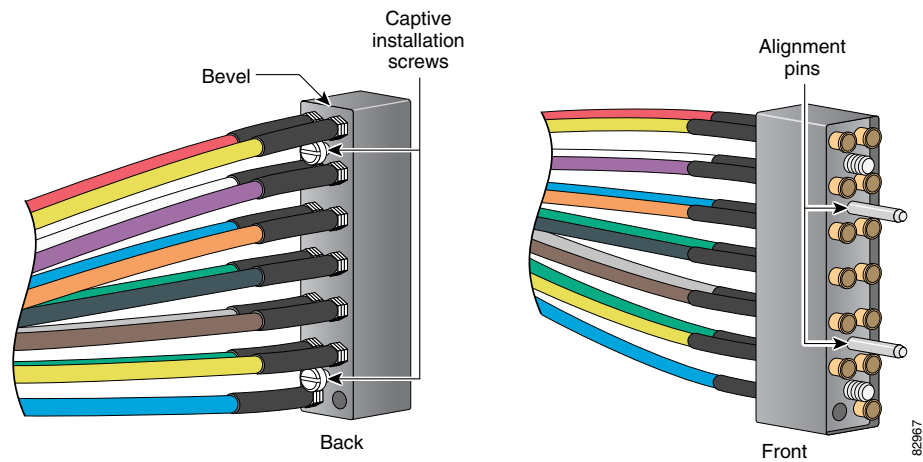

Caution

To ensure proper installation and avoid poor connections, be sure that the cables are not positioned at too acute an angle.

Figure 4-16 RF Switch MCX Connector Locations

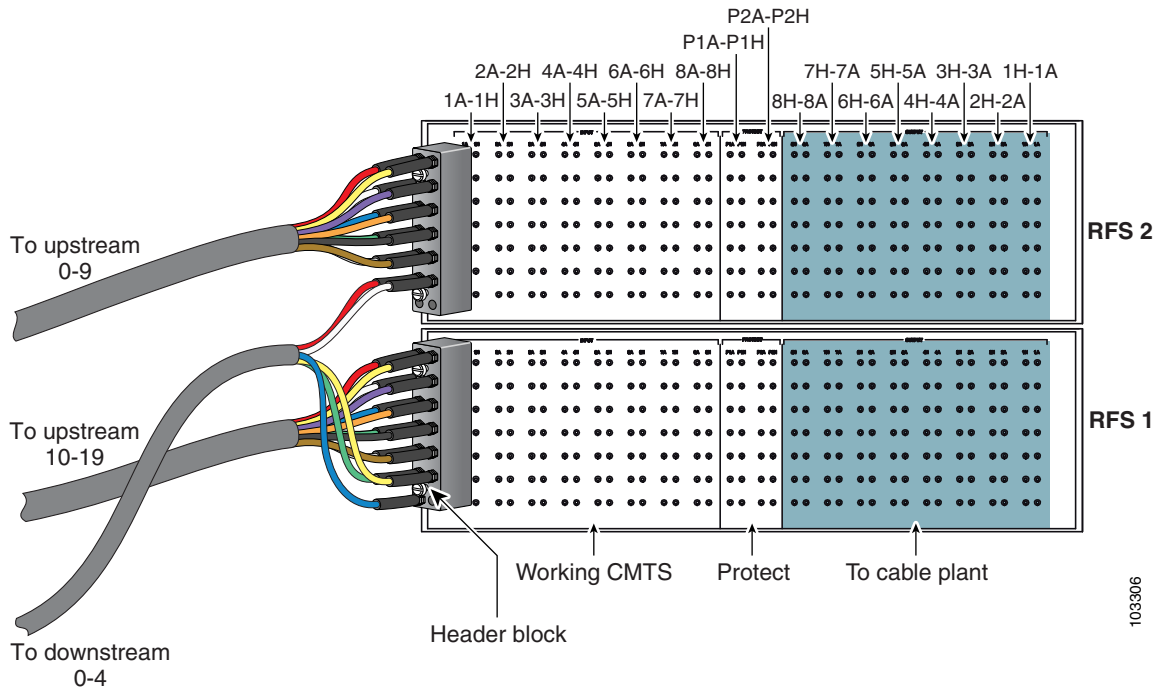

Tip

Alternatively, you can cable the header blocks first, then mount them on the RF switch. Do not fully tighten the header blocks to the RF switch before gently pulling on the cables to be sure that they are firmly seated.

Cisco cables are color-coded for easy reference and installation. The cable color corresponds to a specific port on the card. The tables include a column for users to define ports and color definitions.

See Table 4-11 for a list of the cable ports and associated cable color applicable when using MC5X20 dual/quad-shielded 10-color cables.

Table 4-11 MC5X20 Dual/Quad-Shielded 10-Color Cable Ports and Cable Colors

Universal Cable Holder (1)			Universal Cable Holder (2)			Universal Cable Holder (3)		
Line Card Port	Cable Color	RF Switch User Defined	Line Card Port	Cable Color	RF Switch User Defined	Line Card Port	Cable Color	RF Switch User Defined
US ¹ 0	Red		US10	Gray		DS ² 0	Red	
US1	White		US11	Brown		DS1	White	
US2	Blue		US12	Red		DS2	Blue	
US3	Green		US13	White		DS3	Green	
US4	Yellow		US14	Blue		DS4	Yellow	
US5	Violet		US15	Green		—	—	
US6	Orange		US16	Yellow		—	—	

Table 4-11 MC5X20 Dual/Quad-Shielded 10-Color Cable Ports and Cable Colors (continued)

Universal Cable Holder (1)			Universal Cable Holder (2)			Universal Cable Holder (3)		
Line Card Port	Cable Color	RF Switch User Defined	Line Card Port	Cable Color	RF Switch User Defined	Line Card Port	Cable Color	RF Switch User Defined
US7	Black		US17	Violet		—	—	
US8	Gray		US18	Orange		—	—	
US9	Brown		US19	Black		—	—	

1. US = upstream
2. DS = downstream

Cabling the Output Cables (CABLE PLANT to HUB)

This section describes cabling the RF switch for output.

CABLE PLANT cable headers are wired in the reverse sequence of the CMTS and PROTECT headers (see [Figure 4-17 on page 4-30](#)). Use the same connection methods as described in:

- [“Mapping the Working and Protect Cisco uBR10-MC5X20S/U/H Line Cards RF Cables to the RF Switch” section on page 4-21](#)
- [“Connecting the RF Cables \(Cisco uBR10-MC5X20S/U/H\)” section on page 4-26](#)



Note

CABLE PLANT slots on the Cisco uBR 3x10 RF Switch are numbered in reverse sequence from CMTS and PROTECT. Slot number one is on the far right. Refer to [Figure 4-17 on page 4-30](#) for header block and cable designations as viewed from the cable side of the header blocks.

Equipment

- 7 RF cable kit: CAB-RFSW520TPMF (RFS to cable plant, MCX to F, two 10-bundle, one 5-bundle)
- 14 header blocks provided with input cable kits

To cable the output connections, complete the following steps. See [Figure 4-17 on page 4-30](#).

- Step 1** Install the header blocks on the CABLE PLANT section of the RF switch.
- Step 2** Install the output cables in the header blocks. Refer to the [“Connecting the RF Cables \(Cisco uBR10-MC5X20S/U/H\)” section on page 4-26](#) for MCX connector installation instructions.



Note

The output cables (CABLE PLANT) on the Cisco uBR 3x10 RF Switches are cabled in the reverse order of the input cables (CMTS).

- Step 3** Run the output cables (H–A) from header blocks to splitters, US laser receivers, or the low side of the diplex filters.
- Step 4** Run the output cables (M, F, G) to the splitters/combiners, DS laser transmitters, or the high side of the diplex filters.



Note

N is not used.

Figure 4-17 Wiring the Cable Plant Cable Headers (CMTS/Protect Headers Shown for Comparison)

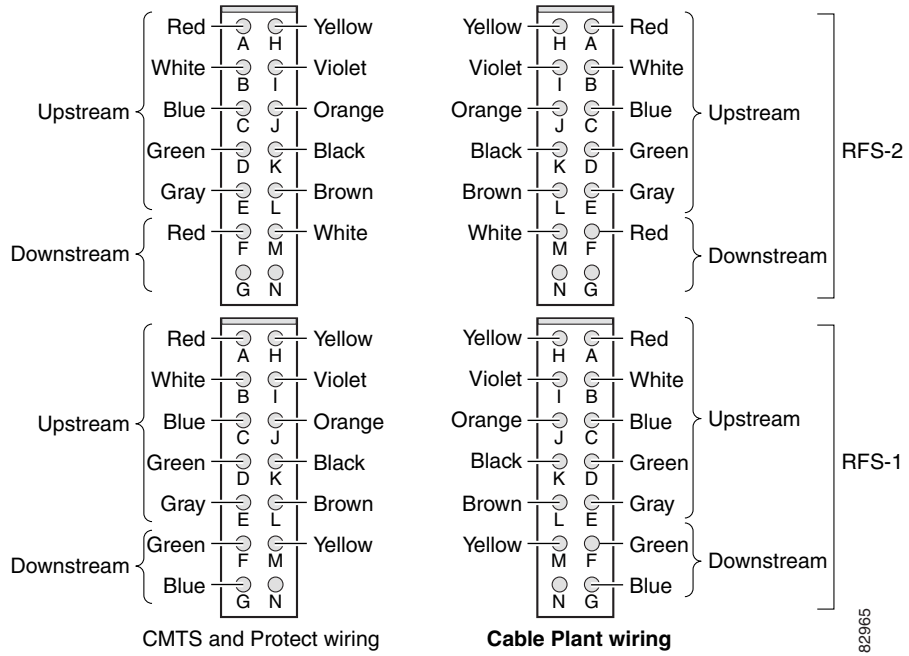

Powering On the RF Switch

To power on the RF switch, complete the following steps.

-
- Step 1** Check that the cables connecting the cable interface line cards in the Cisco uBR10012 CMTS to the Cisco uBR 3x10 RF Switch are in place.
- Step 2** Verify that the power cables are properly connected and secured.
- a. The AC-input power cable is connected and secured with the cable-retention clip.
 - b. The AC power cord is connected to the AC power source.
- or
- a. The DC-input leads (+48 and –48 DC) are connected and secured in the strain-relief on the power supply faceplate.
 - b. The DC ground wire is securely connected to the ground location (rack).
 - c. The DC leads are connected to the DC power source.
- Step 3** Place the power switch on the power supply in either the AC or DC position, depending on which type of power source is connected to your RF switch. The green LED on the power supply comes on.
- Step 4** During the boot process, monitor the Cisco uBR 3x10 RF Switch system initialization and LED behavior for any errors or failures.
-



CHAPTER 5

Cabling the RF Switch With the Cisco uBR7246VXR CMTS

This chapter provides information about connecting cables between the Cisco uBR 3x10 RF Switch and working and protect cable interface line cards in a Cisco uBR7246VXR CMTS.

This chapter contains the following sections:

- [Protection Scheme for the Cisco uBR7246VXR CMTS, page 5-1](#)
- [RF Cable Assemblies, page 5-4](#)
- [Mapping the Working and Protect Line Cards to the RF Switch, page 5-6](#)
- [Installing the Header Blocks on the Cisco uBR 3x10 RF Switch, page 5-7](#)
- [Connecting the Cables \(Cisco uBR-MC16x Card\), page 5-8](#)
- [Connecting the Cables \(Cisco uBR-MC28x Line Card\), page 5-16](#)
- [Powering On the RF Switch, page 5-26](#)

Protection Scheme for the Cisco uBR7246VXR CMTS

The N+1 redundancy protection scheme you select for your system depends upon the number of Cisco uBR7246VXR routers and the number and type of cable interface line cards (LC) you have installed in each Cisco uBR7246VXR router.

The 4+1 redundancy scheme in the example configuration ([Figure 5-1 on page 5-2](#)) shows the Cisco uBR-MC16x cable interface line cards (16 downstream ports and 96 upstream ports) installed in the four Cisco uBR7246VXR routers. The fifth router in the rack (also with MC16x cards) serves as the protect router. The same configuration scenario is true for the Cisco uBR-MC28C cable interface line card; however, the cabling between the line cards and the RF switch is different.

As an example, the first working line card (LC1 in routers 1, 2, 3, and 4) is protected by the first line card (LC1) in the Cisco uBR7246VXR protect router. The second working line card (LC2 in routers 1, 2, 3, and 4) is protected by LC2 in protect router, and so on.

Cisco uBR7246VXR Universal Broadband Router Configurations

A single Cisco uBR7246VXR router contains up to four Cisco uBR-MC16x (C, E, S, U, or X) line cards or Cisco uBR-MC28x (C, U, or X) line cards. This configuration uses a redundancy scheme where one protect card supports from one to four working line cards.

Note

The Cisco uBR-MC16U cable interface line cards have onboard upconverters. Upconverters are not required in a configuration using this line card.

Figure 5-1 Racked Cisco uBR7246VXR Routers, RF Switch, and Upconverters (MC16x)

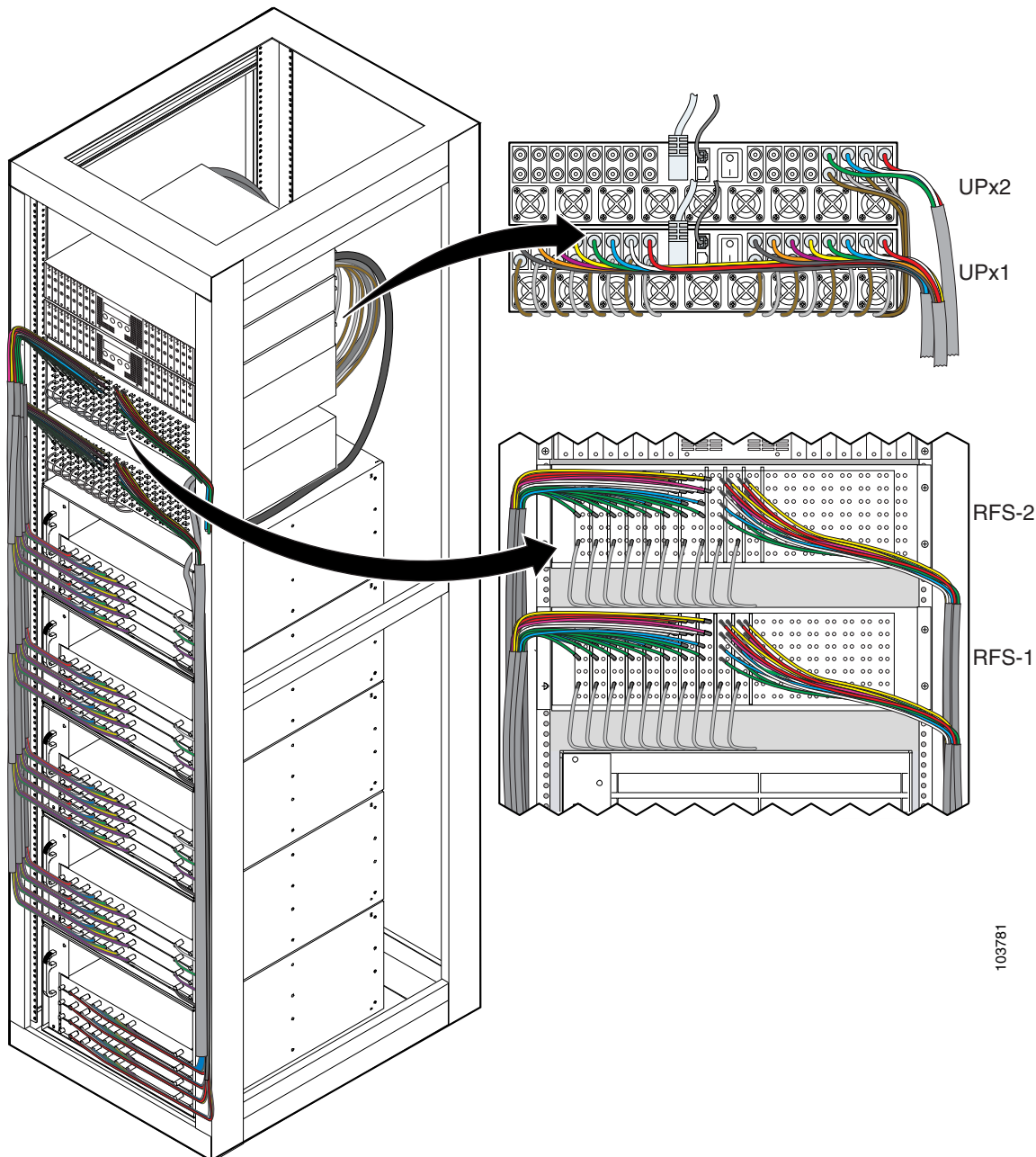
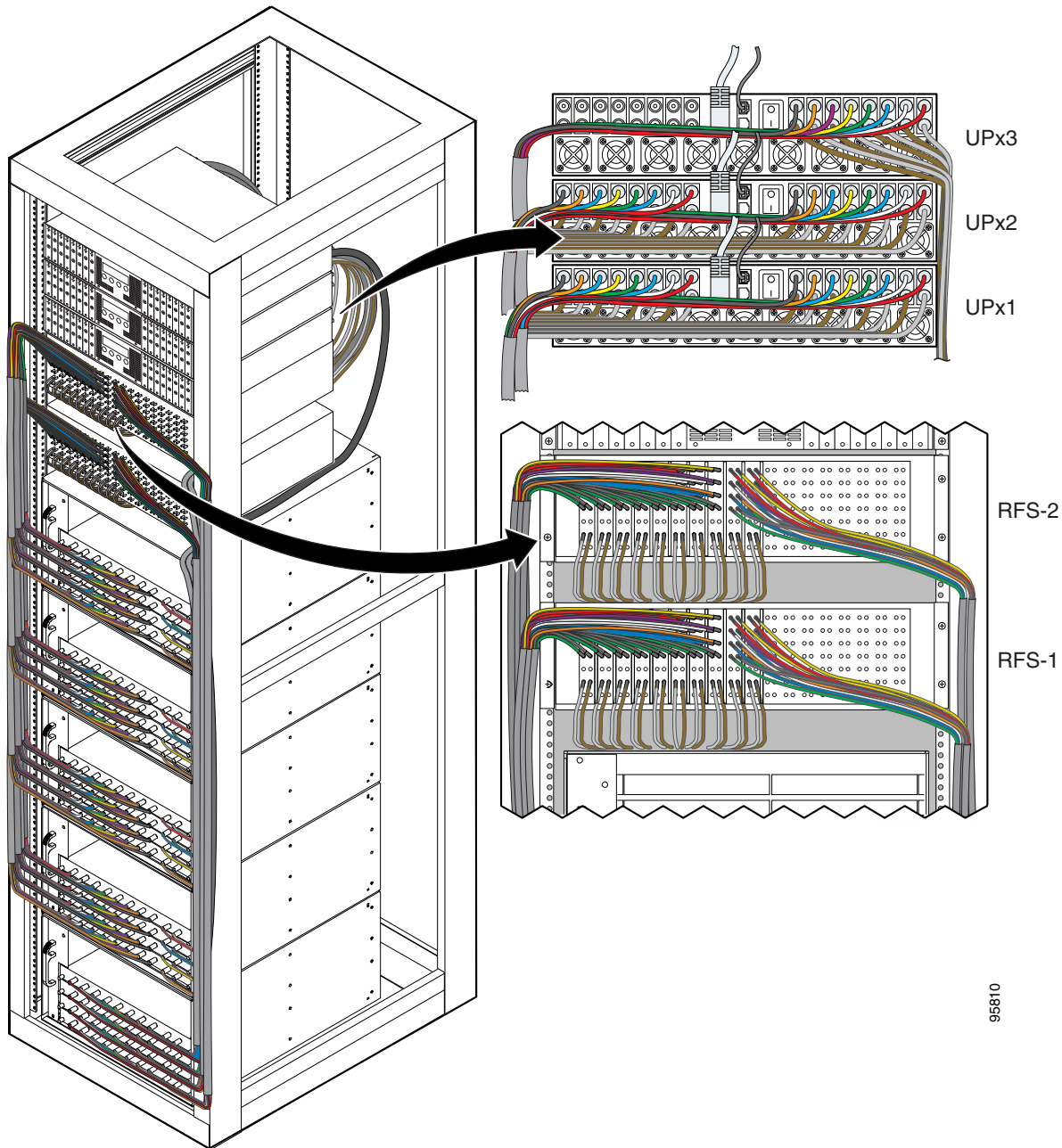

Figure 5-2 shows a chassis configuration using Cisco MC28C cards, two RF switches, and three upconverters. Three upconverters are required for this configuration.

**Note**

The Cisco uBR-MC28U cable interface line cards have onboard upconverters. Upconverters are not required in a configuration using this line card.

Figure 5-2 Racked Cisco uBR7246VXR Routers, RF Switches, and Upconverters (MC28C)



RF Cable Assemblies

The following sections describe the coaxial cable, header block, and F-connector assemblies required to support N+1 redundancy between the Cisco uBR 3x10 RF Switch, the Cisco uBR7246VXR CMTSs and the Vecima HD4040 series IF-to-RF upconverters.



Note

Although you may construct and implement your own cables, we recommend using the preassembled cables and cable bundles.

Custom cables or cable components such as header blocks, crimping tools, or connectors are available from custom cable fabricators such as WhiteSands Engineering (telephone: 1 800-586 7377), at the following URL:

<http://www.whitesandsengineering.com/>

For more information on Vecima HD4040 series IF-to-RF upconverters, go to the following URL:

<http://www.vecima.com>

Coaxial Cables (Single and Bundle)

The cables approved for use in the Cisco N+1 redundancy solution, are Mini Precision RG59 (95 percent) tinned copper braid with (100 percent) foil shield. This cable is serial digital interface (SDI) rated with a 1 MHz to 3 GHz rating.

- CAB-RFSW-3x10-T (bundled cable kit: 1.2-m, CMTS to RFS, F to MCX)
- CAB-RFSW-3x10-10T (bundled cable kit: 10-m, RFS to HUB, MCX to F)
- CAB-RFSW5X20TPMF (bundled cable kit, 3-m, MCX to F)

The different jacket colors are used for easy identification. The gray and brown RF cables are preterminated with the F-connectors used to connect to the Vecima HD4040 series IF-to-RF upconverter input. (See [Figure 5-3](#) and [Figure 5-4](#) on page 5-5.)

Figure 5-3 Cabling Solution for the Cisco RF Switch and Cisco uBR-MC16x Cards

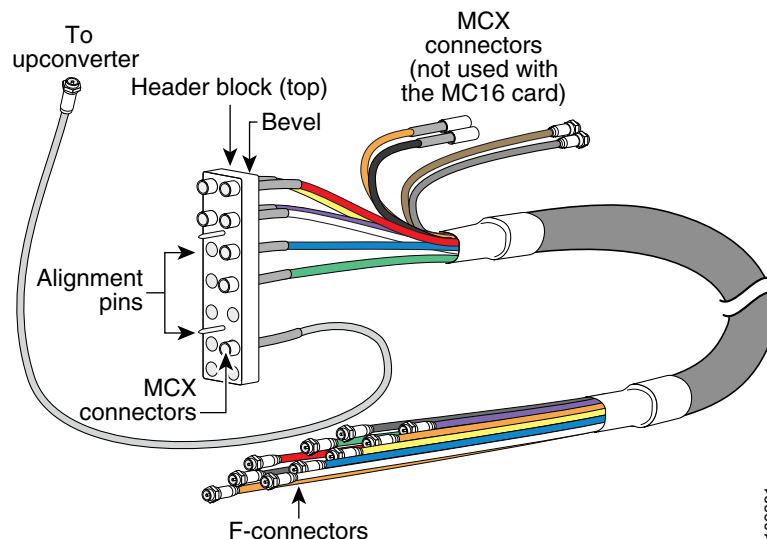
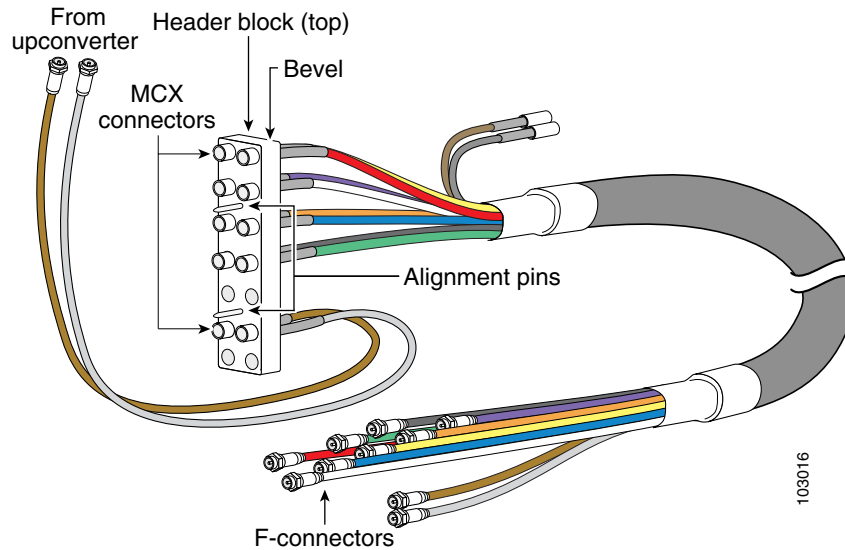

Figure 5-4 Cabling Solution for the Cisco RF Switch and Cisco uBR-MC28C Cards**Table 5-1** Cable Types and the Number of Cable Bundles and Cables Required

Cables (from-to)	Connector Type	Cisco uBR-MC16x	Cisco uBR-MC28C
US ports to RF ports	F-connector to MCX connector	20 cable bundles (multicolor)	20 cable bundles (multicolor)
DS ports to UPx ports	F-connector to F-connector	3 cable bundles (multicolor)	5 cable bundles (multicolor)
UPx ports to RF ports	F-connector to MCX connector	20 single cables (gray, brown)	40 single cables (gray, brown)
RF switch output to CABLE PLANT	MCX connector to F-connector	20 cable bundles (multicolor)	20 cable bundles (multicolor)

Header Blocks

The header blocks are installed on the Cisco uBR 3x10 RF Switch. Individual cables are attached to the MCX connectors in the header blocks (see [Figure 5-4](#)). The header blocks used in this cabling solution are slightly beveled at the top for easy identification. In addition, the alignment pins on the header blocks are offset, preventing you from accidentally connecting the header block upside down.

MCX Connectors and F-Connectors

MCXFP—75-ohm MCX connector available from WhiteSands Engineering or alternate. This connector is attached to the end of the cable that terminates at the Cisco uBR 3x10 RF Switch.

ASFP or alternate—F-connectors available from WhiteSands Engineering. This connector is attached to the end of the cables that terminate at the upstream and downstream ports on the cable interface line cards. The output cabling kit includes 13 F-connectors to use for modification or repair.



Note

An extraction tool used to remove MCX connectors from the header blocks is shipped with the RF switch.

Attenuators

A 10-dB attenuator may be required (due to a higher IF output, +42 dBmV), between the line card and the upconverter IF input ports.

Mapping the Working and Protect Line Cards to the RF Switch

Mapping is applicable for both working and protect cable interface line cards when employing N+1 redundancy. The distinction between which line card serves as the protect line card and which serve as the working line cards is determined by whether the header block is plugged into a working group (CMTS) or protect group (PROTECT) of slots on the RF switch, and by the configuration you specify.

Use these guidelines to map the cables between each Cisco uBR7246VXR router, the RF switch, and the external upconverter:

- All cards in the hot standby communication-to-communication protocol (HCCP) group (protect card and working cards) must be the same type of card. For example: an MC16C working card must use an MC16C protect card.
- Colored cables are used to help facilitate the cabling process. Any color is acceptable as long as it meets the cable specifications. If you are using colored cables, connect the same colored cable to the same port on each of the cable interface line cards in each of the Cisco uBR7246VXR routers. Example: The red cable in each bundle goes to the US0 port on each card.
- Each header block supports one line card. Each header block is cabled exactly the same. For example: The red cables on the US0 ports (applies to all the line cards) go to the “1A, 2A, 3A (.....)8A” connector locations.
- If you are using an external upconverter, the DS ports on the line cards are cabled to the external upconverter first, then cabled from the upconverter to the RF switch.
- The RF switch MCX connections labeled F, G, and M are used only for downstream connection. The downstream cables from the upconverter can be connected to any one of the three available downstream MCX connections. F is the preferred connection point for Cisco uBR-MC16x cards.
- The MCX connection labeled N on the header block does not connect to anything in the Cisco uBR 3x10 RF Switch and should not be connected to any cable interface port either.

Before you cable the CMTS (Cisco uBR7246VXR routers) to the Cisco uBR 3x10 RF Switch, review the [“Connecting the Cables \(Cisco uBR-MC16x Card\)”](#) section on page 5-8 or the [“Connecting the Cables \(Cisco uBR-MC28x Line Card\)”](#) section on page 5-16.

Refer to the “N+1 Redundancy for the Cisco CMTS” chapter of the *Cisco Cable Modem Termination System Feature Guide* for information about system configuration



Tip

Use the color designations to help determine a cable location, US0–red, US1–white, and so on. For the Cisco uBR-MC16x card cable color information, refer to [Table 5-2 on page 5-9](#). For the Cisco uBR-MC28C card cable color information, refer to [Table 5-11 on page 5-17](#).

The output cables are connected to the CABLE PLANT section of the RF switch. The CABLE PLANT header blocks are wired in the opposite sequence to the CMTS and PROTECT header blocks (CABLE PLANT—1H–1A).



Note

Slot number one (CABLE PLANT—1H–1A) is located on the far right.

Installing the Header Blocks on the Cisco uBR 3x10 RF Switch

This section describes attaching the header blocks to the RF switch.

The RF cables are connected to the CMTS, PROTECT, and CABLE PLANT portions of the Cisco uBR 3x10 RF Switch using the header blocks. Header blocks are installed on the RF switch at the following locations:

- CMTS—RF cables connect to working cable interface line cards and to IF-to-RF upconverters.
- PROTECT—RF cables connect to protecting cable interface line cards
- CABLE PLANT—RF cables connect to the cable headend or hub.

Equipment

- 36 header blocks
- Flat-blade screwdriver

To install header blocks, complete the following steps.

-
- Step 1** With the beveled edge of the header block at the top, line up the two alignment pins on the header block with the two holes corresponding to the RF connector group under the CMTS, PROTECT, or CABLE PLANT section of the Cisco uBR 3x10 RF Switch.
- Step 2** Press the header block into place, using equal pressure on both the upper and lower portions of the header block.
- Step 3** Use a flat-blade screwdriver to tighten the captive installation screws at both the top and bottom of the header block to prevent accidental disconnections.



Note

Tighten the header blocks to the Cisco uBR 3x10 RF Switch only after gently pulling on the cables to be sure that they are firmly seated in the header block.



Caution

Do not overtighten the captive screws. We recommend that you tighten the screws to 5 to 7 inch-pounds (0.5647 to 0.7909 nm)

Figure 5-5 Header Block Description

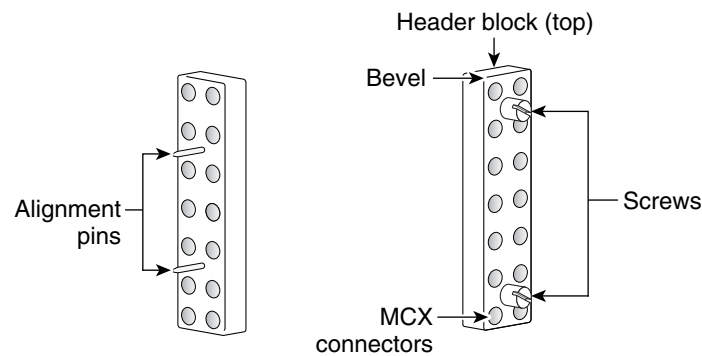

Connecting the Cables (Cisco uBR-MC16x Card)

This section describes one method of cable management using the sample configuration for the Cisco uBR7246VXR with the Cisco uBR-MC16x (C, E, S, U, X) line cards installed.



Tip

Cable the line card to the RF switch header block one card at a time.

RF cables are connected to the CMTS, PROTECT, and CABLE PLANT sections on the rear panel of the Cisco uBR 3x10 RF Switch using a header block. There are:

- 16 RF connection groups under CMTS—These groups of RF cables connect to cable interface line cards designated as the working line cards and to IF-to-RF upconverters.
- 4 RF connection groups under PROTECT—These groups of RF cables connect to cable interface line cards designated as the protect line cards.
- 16 RF connection groups under CABLE PLANT—These groups of RF cables connect to the coaxial or fiber-optic cable transceivers (in the upstream direction) and IF-to-RF upconverters (in the downstream direction) at the cable headend or HUB.

Cabling the Working Line Card (VXR1–VXR4)

This section describes cabling the working line cards from the Cisco uBR7246VXR routers to the RF switch.

Equipment

- 16 cable bundles—4 per router (F-connector to MCX connector—multicolor)
- 16 header blocks (installed)

To cable the working line cards, complete the following steps. Refer to [Table 5-2](#), [Table 5-3](#), [Table 5-4](#), and [Table 5-5](#).

-
- Step 1** Connect the cables to the upstream connectors (US0–US5) on the line cards in VXR1. Tighten the F-connectors to a value between 10 (recommended) and 15 (maximum) inch-pounds (1.1298 nm and 1.7339 nm).
- Step 2** Secure the cables with cable wrap, as necessary, and run the cable bundles up the left side of the equipment rack.
- Step 3** Install the cables in the CMTS header block in the order that they were mapped.
- a. Push the MCX connector into the hole in the header block until you can feel it snap into place.
 - b. Gently wiggle the connector to make sure that the connection is secure.
- Step 4** Repeat [Step 1](#) through [Step 3](#) for each line card in each Cisco uBR7246VXR (VXR2 through VXR4).
-



Note

One cable bundle is used for the US ports on each card. DS ports use a different cable bundle.

Figure 5-6 Cabling the Working Line Cards (VXR1)

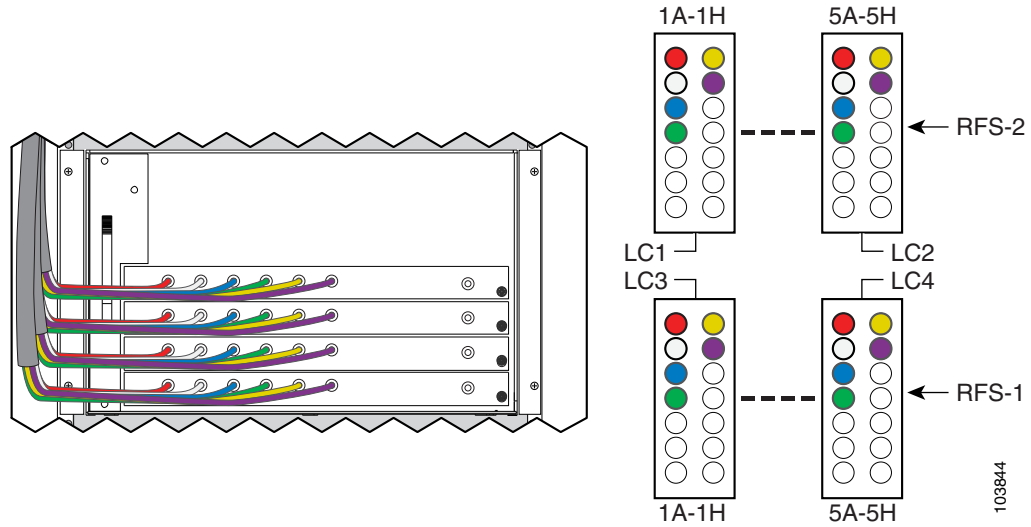

Table 5-2 Cable Bundle Colors Used for US-MCX Connections VXR1 to RFS

Cable Color	US Ports	LC1 to RFS-2	✓	LC2 to RFS-2	✓	LC3 to RFS-1	✓	LC4 to RFS-1	✓
Red	US0	RFS-2—1A		RFS-2—5A		RFS-1—1A		RFS-1—5A	
White	US1	RFS-2—1B		RFS-2—5B		RFS-1—1B		RFS-1—5B	
Blue	US2	RFS-2—1C		RFS-2—5C		RFS-1—1C		RFS-1—5C	
Green	US3	RFS-2—1D		RFS-2—5D		RFS-1—1D		RFS-1—5D	
Yellow	US4	RFS-2—1H		RFS-2—5H		RFS-1—1H		RFS-1—5H	
Violet	US5	RFS-2—1I		RFS-2—5I		RFS-1—1I		RFS-1—5I	

Table 5-3 Cable Bundle Colors Used for US-MCX Connections VXR2 to RFS

Cable Color	US Ports	LC1 to RFS-2	✓	LC2 to RFS-2	✓	LC3 to RFS-1	✓	LC4 to RFS-1	✓
Red	US0	RFS-2—2A		RFS-2—6A		RFS-1—2A		RFS-1—6A	
White	US1	RFS-2—2B		RFS-2—6B		RFS-1—2B		RFS-1—6B	
Blue	US2	RFS-2—2C		RFS-2—6C		RFS-1—2C		RFS-1—6C	
Green	US3	RFS-2—2D		RFS-2—6D		RFS-1—2D		RFS-1—6D	
Yellow	US4	RFS-2—2H		RFS-2—6H		RFS-1—2H		RFS-1—6H	
Violet	US5	RFS-2—2I		RFS-2—6I		RFS-1—2I		RFS-1—6I	

Table 5-4 Cable Bundle Colors Used for US-MCX Connections V XR3 to RFS

Cable Color	US Ports	LC1 to RFS-2	✓	LC2 to RFS-2	✓	LC3 to RFS-1	✓	LC4 to RFS-1	✓
Red	US0	RFS-2—3A		RFS-2—7A		RFS-1—3A		RFS-1—7A	
White	US1	RFS-2—3B		RFS-2—7B		RFS-1—3B		RFS-1—7B	
Blue	US2	RFS-2—3C		RFS-2—7C		RFS-1—3C		RFS-1—7C	
Green	US3	RFS-2—3D		RFS-2—7D		RFS-1—3D		RFS-1—7D	
Yellow	US4	RFS-2—3H		RFS-2—7H		RFS-1—3H		RFS-1—7H	
Violet	US5	RFS-2—3I		RFS-2—7I		RFS-1—3I		RFS-1—7I	

Table 5-5 Cable Bundle Colors Used for US-MCX Connections VXR4 to RFS

Cable Color	US Ports	LC1 to RFS-2	✓	LC2 to RFS-2	✓	LC3 to RFS-1	✓	LC4 to RFS-1	✓
Red	US0	RFS-2—4A		RFS-2—8A		RFS-1—4A		RFS-1—8A	
White	US1	RFS-2—4B		RFS-2—8B		RFS-1—4B		RFS-1—8B	
Blue	US2	RFS-2—4C		RFS-2—8C		RFS-1—4C		RFS-1—8C	
Green	US3	RFS-2—4D		RFS-2—8D		RFS-1—4D		RFS-1—8D	
Yellow	US4	RFS-2—4H		RFS-2—8H		RFS-1—4H		RFS-1—8H	
Violet	US5	RFS-2—4I		RFS-2—8I		RFS-1—4I		RFS-1—8I	

Figure 5-7 Cabling the Working Line Cards to the RF Switch

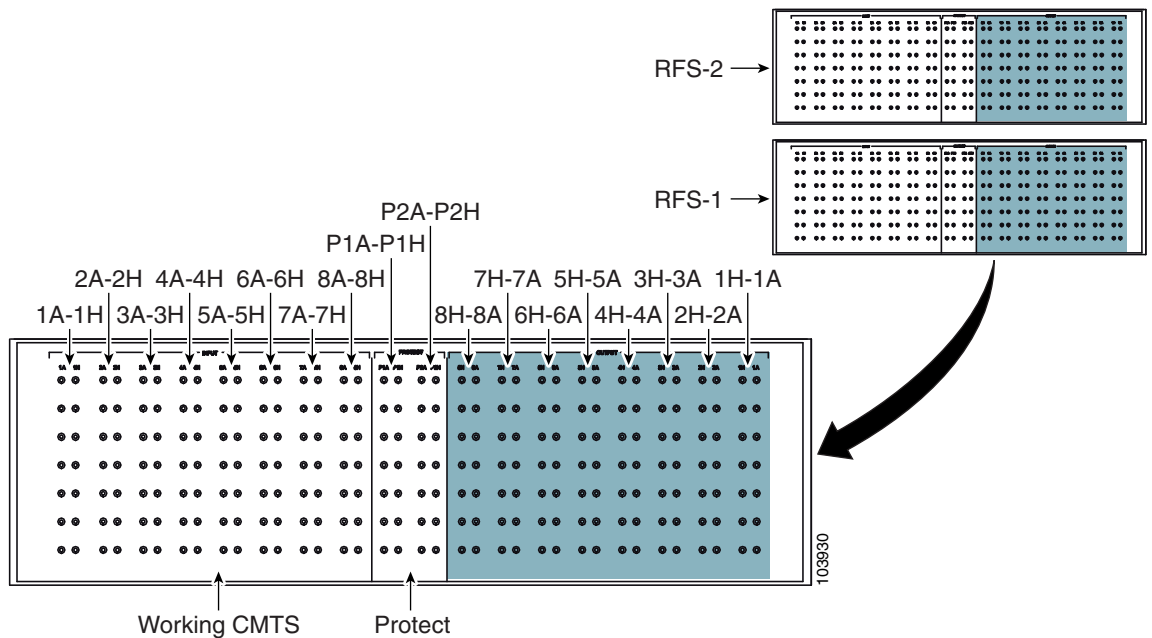

The following tables provide chassis–line card to RF switch relationships.

Table 5-6 Cable Bundle Sequence for VXR1–VXR2 to Cisco uBR 3x10 RF Switches (1 and 2)

VXR1–LC	RFS Slot (Header Block)	VXR2–LC	RFS Slot (Header Block)
LC1(US0–US5)	RFS-2 Slot 1 (1A–1I)	LC1(US0–US5)	RFS-2 Slot 2 (2A–2I)
LC2(US0–US5)	RFS-2 Slot 5 (5A–5I)	LC2(US0–US5)	RFS-2 Slot 6 (6A–6I)
LC3(US0–US5)	RFS-1 Slot 1 (1A–1I)	LC3(US0–US5)	RFS-1 Slot 2 (2A–2I)
LC4(US0–US5)	RFS-1 Slot 5 (5A–5I)	LC4(US0–US5)	RFS-1 Slot 6 (6A–6I)

Table 5-7 Cable Bundle Sequence for VXR3–VXR4 to Cisco uBR 3x10 RF Switches (1 and 2)

VXR3–LC	RFS Slot (Header Block)	VXR4–LC	RFS Slot (Header Block)
LC1(US0–US5)	RFS-2 Slot 3 (3A–3I)	LC1(US0–US5)	RFS-2 Slot 4 (4A–4I)
LC2(US0–US5)	RFS-2 Slot 7 (7A–7I)	LC2(US0–US5)	RFS-2 Slot 8 (8A–8I)
LC3(US0–US5)	RFS-1 Slot 3 (3A–3I)	LC3(US0–US5)	RFS-1 Slot 4 (4A–4I)
LC4(US0–US5)	RFS-1 Slot 7 (7A–7I)	LC4(US0–US5)	RFS-1 Slot 8 (8A–8I)

Cabling the Protect Line Cards (VXR5)

This section describes cabling the protect cable interface line cards from the Cisco uBR7246VXR router to the RF switch.

Equipment

- 4 cable bundles (F-connector to MCX connector—multicolor)
- 4 header blocks (installed)

To cable the protect line cards, complete the following steps. Refer to [Table 5-8](#) and to [Figure 5-8 on page 5-12](#).

-
- Step 1** Connect the cables to the upstream connectors (US0–US5) on line card–LC1 on router 5.
- Step 2** Secure the cables with cable wrap, as necessary, and run the cable bundles up the right side of the equipment rack.
- Step 3** Install the cables in the PROTECT header block in the order that they were mapped. See [Figure 5-8](#).
- Step 4** Repeat [Step 1](#) through [Step 3](#) for all the line cards in VXR5 (PROTECT).
-

Figure 5-8 Cabling the Protect Line Cards (MC16x)

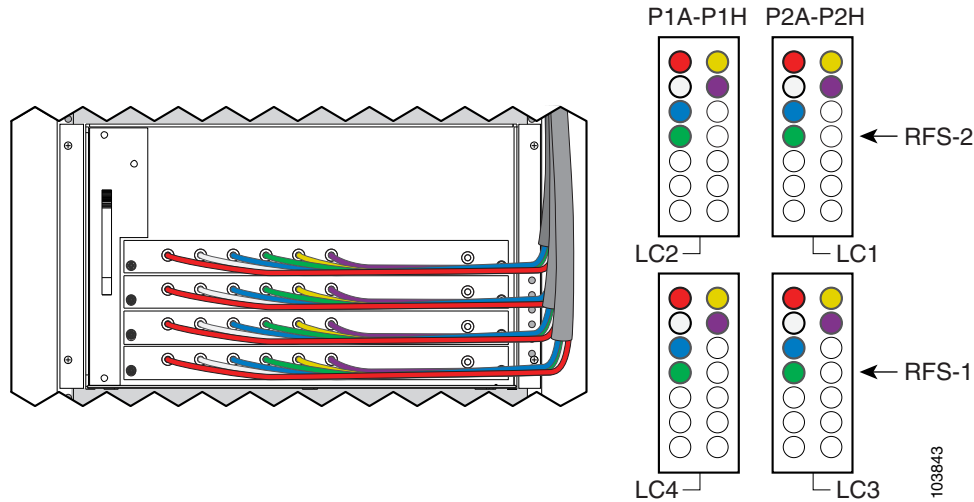

Table 5-8 RF Switch Slots for the PROTECT Cards

VXR5-LC	US Ports	RFS-1—PROTECT Slot	✓	VXR5-LC	US Ports	RFS-2—PROTECT Slot	✓
LC1	US0-US3, US4-US5	RFS-2—P2 (A-D) RFS-2—P2 (H-I)		LC3	US0-US3, US4-US5	RFS-1—P2 (A-D) RFS-1—P2 (H-I)	
LC2	US0-US3, US4-US5	RFS-2—P1 (A-D) RFS-2—P1 (H-I)		LC4	US0-US3, US4-US5	RFS-1—P1 (A-D) RFS-1—P1 (H-I)	

Cabling DS Ports to the Input Ports on the Upconverter

This section describes cabling from the Cisco uBR7246VXR line cards DS ports to the upconverter.



Note

The Cisco uBR-MC16U cable interface line cards have onboard upconverters and are cabled directly to the DS ports (F) on the RF switch.

Equipment

- 3 cable bundles —(F-connector to F-connector—multicolor)

To cable the DS ports, complete the following steps. Refer to [Table 5-9](#) and [Figure 5-9](#) on page 5-13.

- Step 1** Connect the cables to the downstream connectors (DS) on the line cards (LC1–LC4).
- Step 2** Secure the cables with cable wrap, and run the cable bundles up the right side of the equipment rack.
- Step 3** Pull the cable bundle through the space between the VXR1 router and the RF switch. Add a 10-dB attenuator to the DS cables, if necessary.
- Step 4** Connect the cables to the input ports (top) on the upconverter.
- Step 5** Repeat Step 1 through Step 4 for each DS port (VXR2 through VXR5).

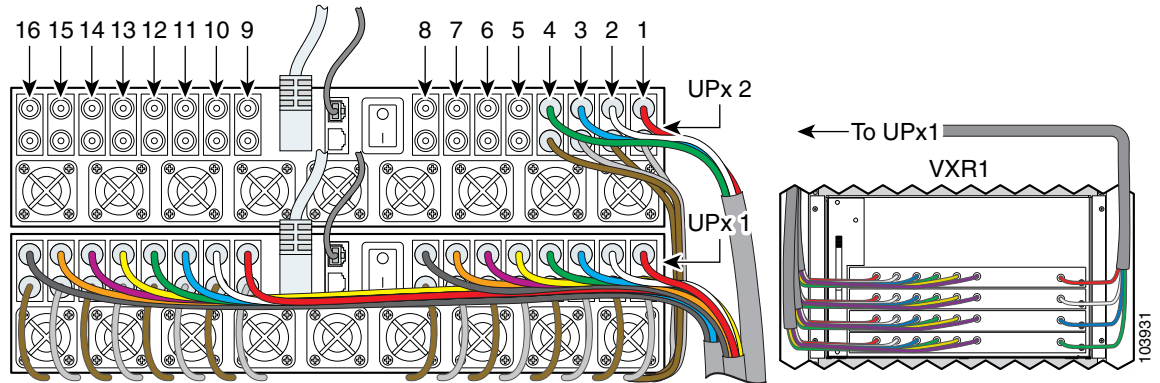
Figure 5-9 Cabling the Upconverter (MC16x to UPx1)**Table 5-9** DS Cables from VXRs to Upconverter Ports (by Router)

Color	VXR1/VXR2	UPx1 Input	✓	VXR3/VXR4	UPx1 Input	✓	VXR5	UPx2 Input	✓
Red	LC1-DS	1		LC1-DS	9		LC1-DS	1	
White	LC2-DS	2		LC2-DS	10		LC2-DS	2	
Blue	LC3-DS	3		LC3-DS	11		LC3-DS	3	
Green	LC4-DS	4		LC4-DS	12		LC4-DS	4	
Yellow	LC1-DS	5		LC1-DS	13		—	—	
Purple	LC2-DS	6		LC2-DS	14		—	—	
Orange	LC3-DS	7		LC3-DS	15		—	—	
Black	LC4-DS	8		LC4-DS	16		—	—	

Cabling the Output Ports (Upconverter to RF Switch)

This section describes cabling from the output ports on the upconverter to the RF switch.

Equipment

- 20 cables (F-connector to MCX connector—gray and brown)

To cable the output ports on the upconverter, complete the following steps. Refer to [Table 5-10](#) and [Figure 5-10](#).

-
- Step 1** Connect the cable to the output connector (1-lower) on the upconverter.
- Step 2** Run the cable under the RF switch to the rear of the chassis.
- Step 3** Connect the cable to the 1F port on RFS-2.
- Step 4** Repeat [Step 1](#) through [Step 3](#) for the remaining cables.
-

Figure 5-10 Output Cables (Gray and Brown)

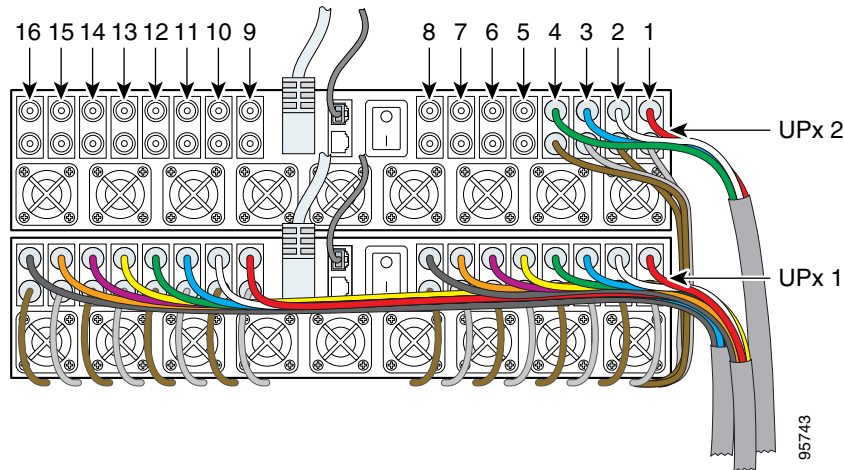

Table 5-10 Upconverter Output Cables (UPx1 and UPx2) to RF Switches (RFS-1 and RFS-2)

Color	UPx	RFS Ports	Supports	✓	UPx	RFS Ports	Supports	✓	UPx	RFS Ports	Supports	✓
Gray	1 ¹	RFS-2-1F	VXR1-LC1		9	RFS-2-3F	VXR3-LC1		1 ²	RFS-2-P2F	VXR5-LC1	
Brown	2	RFS-2-5F	VXR1-LC2		10	RFS-2-7F	VXR3-LC2		2	RFS-2-P1F	VXR5-LC2	
Gray	3	RFS-1-1F	VXR1-LC3		11	RFS-1-3F	VXR3-LC3		3	RFS-1-P2F	VXR5-LC3	
Brown	4	RFS-1-5F	VXR1-LC4		12	RFS-1-7F	VXR3-LC4		4	RFS-1-P1F	VXR5-LC4	
Gray	5	RFS-2-2F	VXR2-LC1		13	RFS-2-4F	VXR4-LC1					
Brown	6	RFS-2-6F	VXR2-LC2		14	RFS-2-8F	VXR4-LC2					
Gray	7	RFS-1-2F	VXR2-LC3		15	RFS-1-4F	VXR4-LC3					
Brown	8	RFS-1-6F	VXR2-LC4		16	RFS-1-8F	VXR4-LC4					

1. Working 1 through 16 are located on UPx1

2. Protect 1 through 4 are located on UPx2

Cabling the Output Cables (CABLE PLANT to HUB)

This section describes cabling the RF switch for output.

Equipment

- 16 cable bundles (MCX connector to F-connector—multicolor)
- 16 header blocks (installed)



Note

Two more cable bundles may be required if you intend to route the upstream cables and the downstream cables to different locations.

To cable the RF switch output cables, complete the following steps. Refer to [Figure 5-11](#).

Step 1 Install the output cables in the header blocks.



Note The output cables (CABLE PLANT) on the Cisco uBR 3x10 RF Switch are cabled in the reverse order of the input cables (CMTS).

Step 2 Run the output cables (H–A) from header blocks to splitters, US laser receivers, or the low side of the diplex filters

Step 3 Run the output cables (F) to the splitters or combiners, DS laser transmitters, or the high side of the diplex filters.

Figure 5-11 RF Switch Cable Plant Outputs (Turquoise)

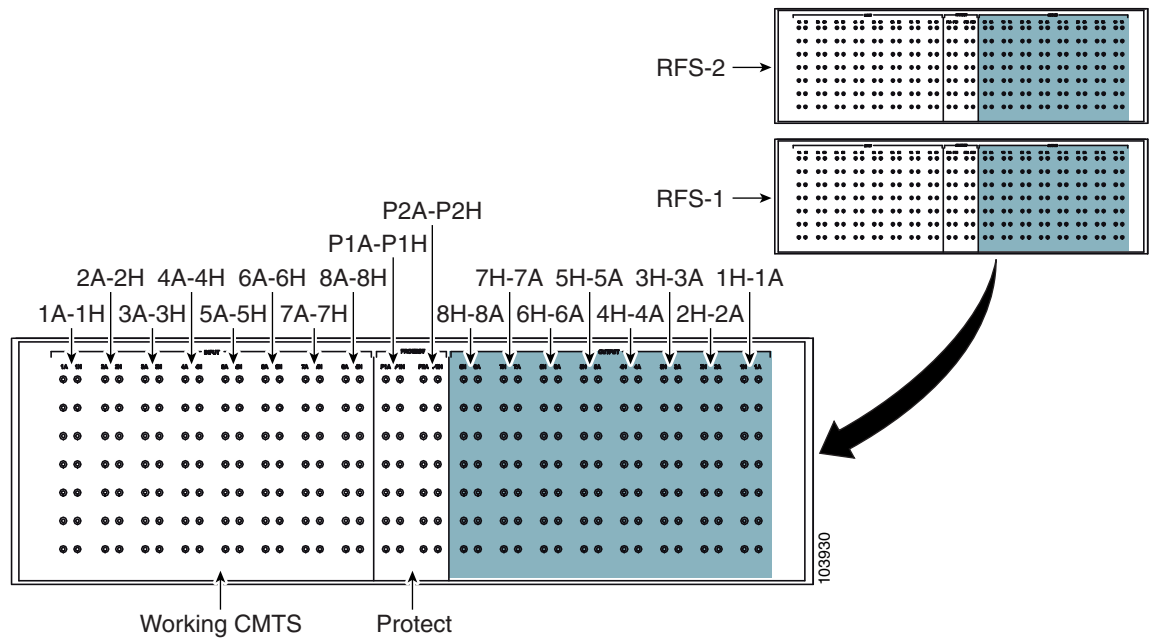

Connecting the Cables (Cisco uBR-MC28x Line Card)

This section describes one method of cable management using the sample configuration for the Cisco uBR7246VXR with the Cisco uBR-MC28x (C, U, X) cards installed.

The RF cables are connected to the CMTS, PROTECT, and CABLE PLANT sections on the rear panel of the two Cisco uBR 3x10 RF Switches using header blocks. There are:

- Thirty-two RF connection groups under CMTS—Each line card is two working groups. These groups of RF cables connect to cable interface line cards and to IF-to-RF upconverters.
- Eight RF connection groups under PROTECT—These groups of RF cables connect to cable interfaces designated as the protect interface.
- Thirty-two RF connection groups under CABLE PLANT—These groups of RF cables connect to the coaxial or fiber-optic cable transceivers (in the upstream direction) and IF-to-RF upconverters (in the downstream direction) at the cable headend or HUB.



Note A connection group is a MAC domain which includes a downstream and its associated upstreams.

Cabling the Working Line Card (VXR1–VXR4)

This section describes cabling the working line cards from the Cisco uBR7246VXR routers to the RF switch.

Equipment

- 16 cable bundles—4 per router, one per card (F-connector to MCX connector—multicolor)
- 16 header blocks (installed)

To cable the working line cards, complete the following steps. Refer to [Table 5-11](#) for the color scheme.

- Step 1** Connect the cables to the upstream ports (US0–US3, US0–US3) on the line cards in VXR1. Tighten the F-connectors to a value between 10 (recommended) and 15 (maximum) inch-pounds (1.1298 nm and 1.7339 nm).



Note Cable and connect to the RF switch, one card at a time. See the [“Installing the Header Blocks on the Cisco uBR 3x10 RF Switch”](#) section on page 5-7, if necessary.

- Step 2** Secure the cables with cable wrap, and run the cable bundles up the left side of the equipment rack.

- Step 3** Install the cables in the CMTS header block in the order that they were mapped.

- a. Carefully follow the cabling directions shown in [Table 5-12](#) and [Table 5-13](#) on page 5-18 for cable locations on the RF switches and the appropriate header block.



Note LC1 and LC2 go to RF switch 2 (RFS-2); LC3 and LC4 go to RF switch 1(RFS-1).

- b. Push the MCX connector into the hole in the header block until you can feel it snap into place.
- c. Gently wiggle the connector to make sure that the connection is secure.

Step 4 Repeat [Step 1](#) through [Step 3](#) for each line card in each Cisco uBR7246VXR (VXR2 through VXR4).

Figure 5-12 Cabling the Cisco uBR-MC28C Line Card in VXR1 to the RF Switches

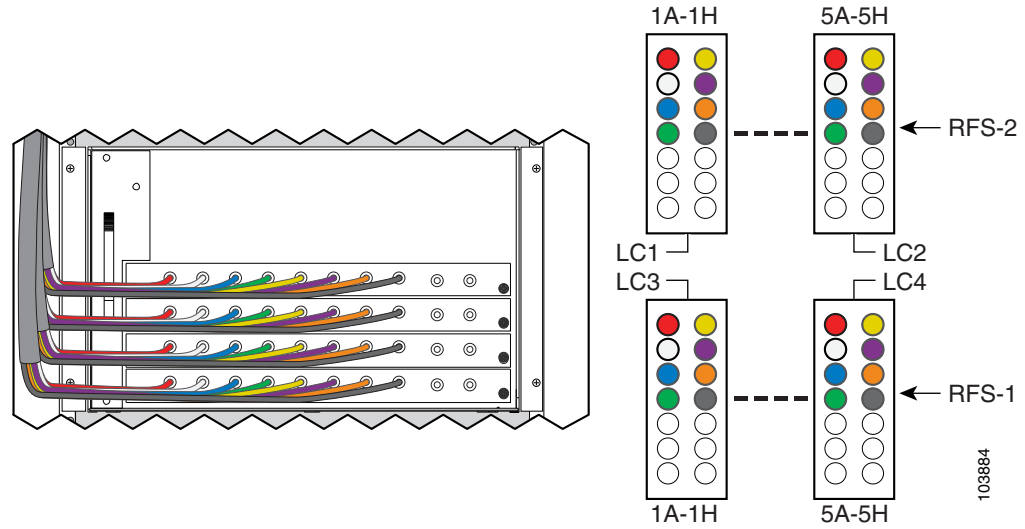

Table 5-11 Cable Bundle Colors Used for Cisco uBR-MC28C US Ports to RFS MCX Connections

Cable Color	US Ports	LC1-RFS-2	✓	LC2-RFS-2	✓	LC3-RFS-1	✓	LC4-RFS-1	✓
Red	US0	1A		5A		1A		5A	
White	US1	1B		5B		1B		5B	
Blue	US2	1C		5C		1C		5C	
Green	US3	1D		5D		1D		5D	
Yellow	US0	1H		5H		1H		5H	
Violet	US1	1I		5I		1I		5I	
Orange	US2	1J		5J		1J		5J	
Black	US3	1K		5K		1K		5K	

RF Switch 2

Table 5-12 Cable Bundle Sequence for the Cisco uBR 3x10 RF Switch 2

VXR1-LC	US Ports	RFS-2 Slot (Header Block)	✓	VXR3-LC	US Ports	RFS-2 Slot (Header Block)	✓
LC1	US0-US3, US0-US3	RFS-2 Slot 1 (1A-1D) RFS-2 Slot 1 (1H-1K)		LC1(US0-US3, US0-US3	RFS-2 Slot 3 (3A-3D) RFS-2 Slot 3 (3H-3K)	
LC2	US0-US3, US0-US3	RFS-2 Slot 5 (5A-5D) RFS-2 Slot 5 (5H-5K)		LC2	US0-US3, US0-US3	RFS-2 Slot 7 (7A-7D) RFS-2 Slot 7 (7H-7K)	

VXR2-LC	US Ports	RFS-2 Slot (Header Block)	✓	VXR4-LC	US Ports	RFS-2 Slot (Header Block)	✓
LC1	US0-US3, US0-US3	RFS-2 Slot 2 (2A-2D) RFS-2 Slot 2 (2H-2K)		LC1	US0-US3, US0-US3	RFS-2 Slot 4 (4A-4D) RFS-2 Slot 4 (4H-4K)	
LC2	US0-US3, US0-US3	RFS-2 Slot 6 (6A-6D) RFS-2 Slot 6 (6H-6K)		LC2	US0-US3, US0-US3	RFS-2 Slot 8 (8A-8D) RFS-2 Slot 8 (8H-8K)	

RF Switch 1

Table 5-13 Cable Bundle Sequence for the Cisco uBR 3x10 RF Switch 1

VXR1-LC	US Ports	RFS-1 Slot (Header Block)	✓	VXR3	US Ports	RFS-1 Slot (Header Block)	✓
LC3	US0-US3, US0-US3	RFS-1 Slot 1 (1A-1D) RFS-1 Slot 1 (1H-1K)		LC3(US0-US3, US0-US3	RFS-1 Slot 3 (3A-3D) RFS-1 Slot 3 (3H-3K)	
LC4	US0-US3, US0-US3	RFS-1 Slot 5 (5A-5D) RFS-1 Slot 5 (5H-5K)		LC4	US0-US3, US0-US3	RFS-1 Slot 7 (7A-7D) RFS-1 Slot 7 (7H-7K)	

VXR2-LC	US Ports	RFS-1 Slot (Header Block)	✓	VXR4-LC	US Ports	RFS-1 Slot (Header Block)	✓
LC3	US0-US3, US0-US3	RFS-1 Slot 2 (2A-2D) RFS-1 Slot 2 (2H-2K)		LC3	US0-US3, US0-US3	RFS-1 Slot 4 (4A-4D) RFS-1 Slot 4 (4H-4K)	
LC4	US0-US3, US0-US3	RFS-1 Slot 6 (6A-6D) RFS-1 Slot 6 (6H-6K)		LC4	US0-US3, US0-US3	RFS-1 Slot 8 (8A-8D) RFS-1 Slot 8 (8H-8K)	

Figure 5-13 Cisco uBR 3x10 RF Switch

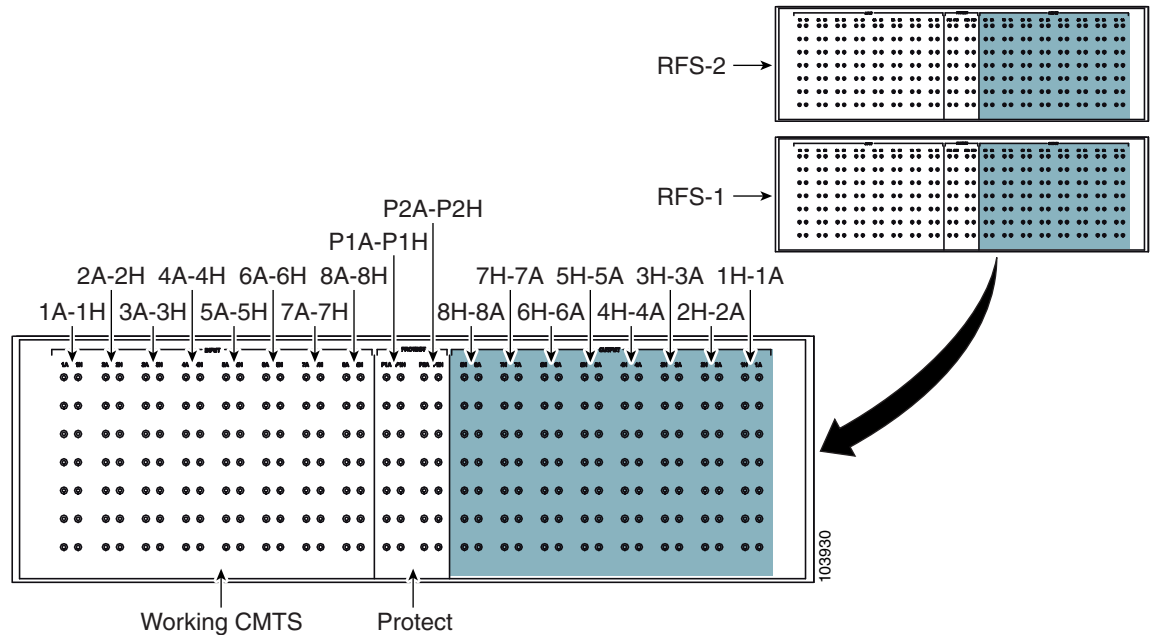

Cabling the Protect Line Cards (VXR 5)

This section describes cabling the protect line cards from the Cisco uBR7246VXR router to the RF switch.

Equipment

- 4 cable bundles—1 per router (F-connector to MCX connector—multicolor)
- 4 header blocks (installed)

To cable the protect line cards, complete the following steps. Refer to [Table 5-14](#) and [Figure 5-14](#).

- Step 1** Connect the cables to the upstream connectors (US0–US3, US0–US3) on line card, LC1 in router 5.
- Step 2** Secure the cables with cable wrap, as necessary, and run the cable bundles up the right side of the equipment rack.
- Step 3** Install the cables in the PROTECT header block in the order that they were mapped.
- Step 4** Repeat [Step 1](#) through [Step 3](#) for all the line cards in VXR5 (PROTECT).

Table 5-14 RF Switch Slots for the PROTECT Cards

VXR5-LC	US Ports	RFS-2—PROTECT Slot	✓	VXR5-LC	US Ports	RFS-1—PROTECT Slot	✓
LC1	US0–US3 US0–US3	RFS-2—P2 (A–D) RFS-2—P2 (H–K)		LC3	US0–US3 US0–US3	RFS-1—P2 (A–D) RFS-1—P2 (H–K)	
LC2	US0–US3 US0–US3	RFS-2—P1 (A–D) RFS-2—P1 (H–K)		LC4	US0–US3 US0–US3	RFS-1—P1 (A–D) RFS-1—P1 (H–K)	

Figure 5-14 Cabling the Protect Line Cards (MC28C)

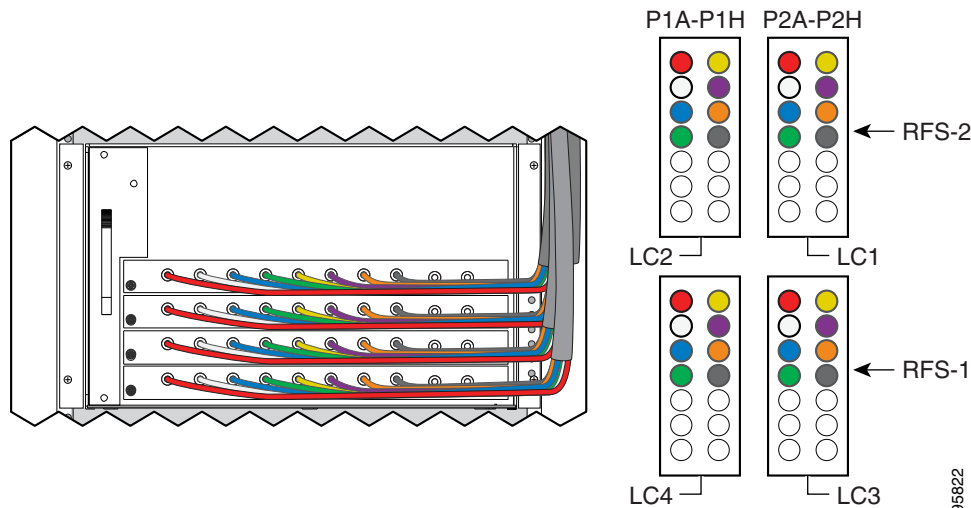

Cabling DS Ports to the Input Ports on the Upconverter

This section describes cabling from the Cisco uBR7246VXR line cards DS ports to the upconverter.



Note

The Cisco uBR-MC28U cable interface line cards have onboard upconverters and are cabled directly to the DS ports (F, M, or G) on the RF switch.

Equipment

- 5 cable bundles —(F-connector to F-connector—multicolor)

To cable the DS ports to the upconverter, complete the following steps. Refer to [Figure 5-15 on page 5-21](#), and [Table 5-15](#), [Table 5-16](#), and [Table 5-17 on page 5-22](#).

-
- Step 1** Connect the cables to the downstream connectors (DS0, DS1) on the line cards (LC1–LC4).
- Step 2** Secure the cables with cable wrap, and run the cable bundles up the right side of the equipment rack.
- Step 3** Pull the cable bundle through the space between the VXR1 router and the RF switch. Add a 10-dB attenuator to the DS cables, if necessary.
- Step 4** Connect the cables to the input ports (top) on the upconverter.
- Step 5** Repeat Step 1 through Step 4 for each DS0 and DS1 port on the Cisco uBR7246VXR routers (VXR2 through VXR5).
-

[Figure 5-15 on page 5-21](#) shows cabling for the upconverter.

- From the DS ports of the line cards to the upconverter—multicolored cables
- From the upconverter to the RF switch—gray and brown cables

Figure 5-15 Cabling the Upconverter

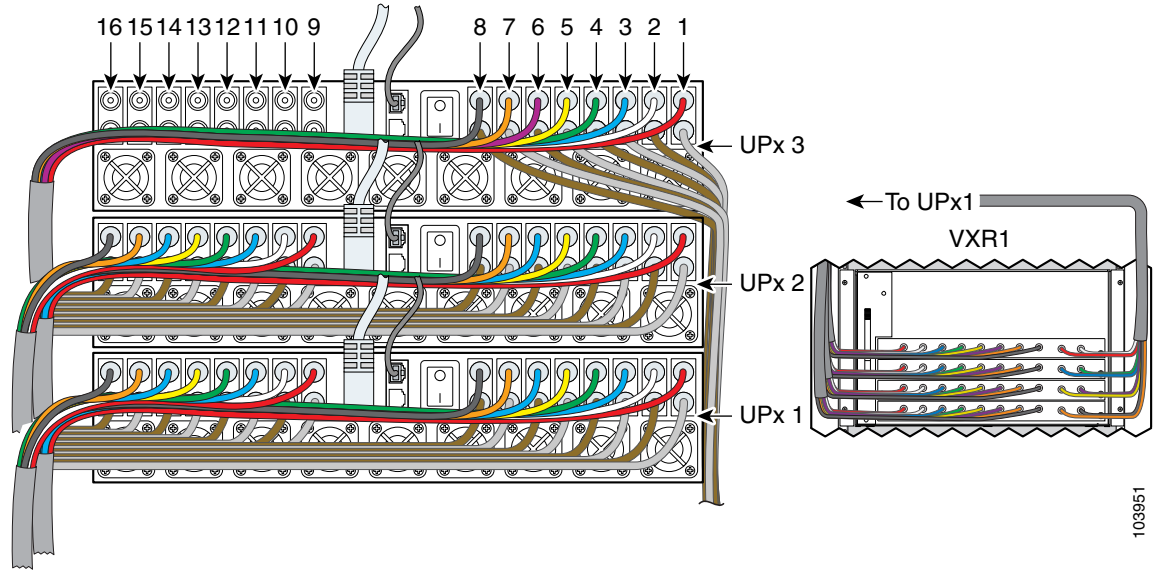

103951

UPx1

Table 5-15 DS Cables from VXRs to UPx1 Ports (by Router)

Color	VXR1	UPx1 Input	✓	VXR2	UPx1 Input	✓
Red	LC1—DS0	1		LC1—DS0	9	
White	LC1—DS1	2		LC1—DS1	10	
Blue	LC2—DS0	3		LC2—DS0	11	
Green	LC2—DS1	4		LC2—DS1	12	
Yellow	LC3—DS0	5		LC3—DS0	13	
Violet	LC3—DS1	6		LC3—DS1	14	
Orange	LC4—DS0	7		LC4—DS0	15	
Black	LC4—DS1	8		LC4—DS1	16	

UPx2

Table 5-16 DS Cables from VXR3 to UPx2 Ports (by Router)

Color	VXR3	UPx2 Input	✓	VXR4	UPx2 Input	✓
Red	LC1—DS0	1		LC1—DS0	9	
White	LC1—DS1	2		LC1—DS1	10	
Blue	LC2—DS0	3		LC2—DS0	11	
Green	LC2—DS1	4		LC2—DS1	12	
Yellow	LC3—DS0	5		LC3—DS0	13	
Violet	LC3—DS1	6		LC3—DS1	14	
Orange	LC4—DS0	7		LC4—DS0	15	
Black	LC4—DS1	8		LC4—DS1	16	

UPx3

Table 5-17 DS Cables from VXR5 to UPx3 Ports (by Router)

Color	VXR5	UPx3 Input	✓
Red	LC1—DS0	1	
White	LC1—DS1	2	
Blue	LC2—DS0	3	
Green	LC2—DS1	4	
Yellow	LC3—DS0	5	
Violet	LC3—DS1	6	
Orange	LC4—DS0	7	
Black	LC4—DS1	8	

Cabling the Output Ports (Upconverter to RF Switch)

The following section describes cabling from the output ports on the upconverter to the RF switch.

Equipment

- 40 cables (F-connector to MCX connector—gray and brown)

To cable the upconverter to the RF switch, complete the following steps. Refer to [Figure 5-15](#).

-
- Step 1** Connect the cable to the output connector (1–lower) on the upconverter.
- Step 2** Run the cable under the RF switch to the rear of the chassis.
- Step 3** Connect the cable to the F1 port on the header block.
- See [Table 5-18 on page 5-24](#) for UPx1.
 - See [Table 5-19 on page 5-24](#) for UPx2.
 - See [Table 5-20 on page 5-24](#) for UPx3.
- Step 4** Repeat [Step 1](#) through [Step 3](#) for the remaining cables, alternating between the F and M ports on the header blocks.
-



Tip

Use different colored cables for each connection. The example shows alternating gray and brown.

Figure 5-16 Output Cables (Gray and Brown)

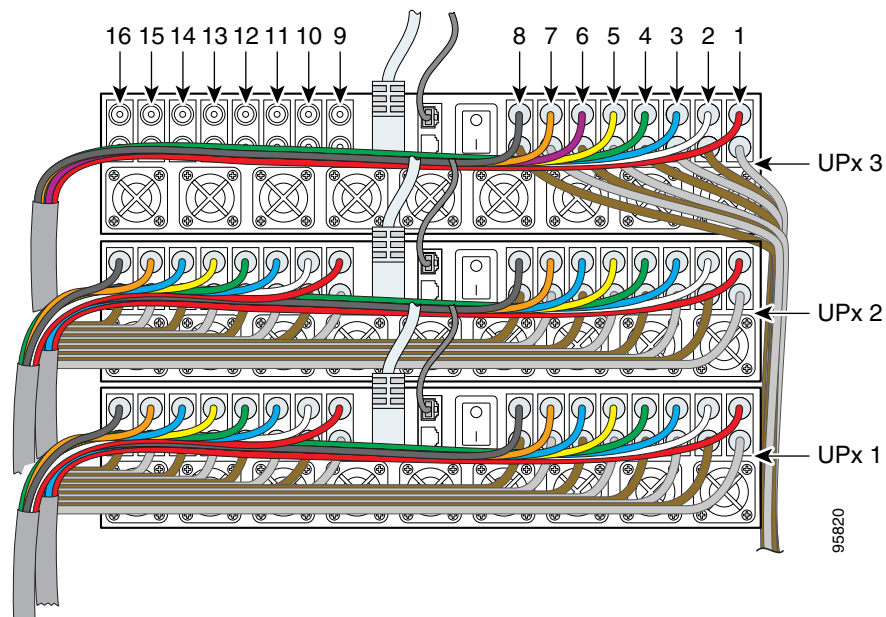

95820

UPx1

Table 5-18 UPx1 Cables to RF Switch

Color	UPx1 Output	RFS Ports	✓	UPx1 Output	RFS Ports	✓
Gray	1	RFS-2, 1F		9	RFS-2, 2F	
Brown	2	RFS-2, 1M		10	RFS-2, 2M	
Gray	3	RFS-2, 5F		11	RFS-2, 6F	
Brown	4	RFS-2, 5M		12	RFS-2, 6M	
Gray	5	RFS-1, 1F		13	RFS-1, 2F	
Brown	6	RFS-1, 1M		14	RFS-1, 2M	
Gray	7	RFS-1, 5F		15	RFS-1, 6F	
Brown	8	RFS-1, 5M		16	RFS-1, 6M	

UPx2

Table 5-19 UPx2 Cables to RF Switch

Color	UPx2 Output	RFS Ports	✓	UPx2 Output	RFS Ports	✓
Gray	1	RFS-2, 3F		9	RFS-2, 4F	
Brown	2	RFS-2, 3M		10	RFS-2, 4M	
Gray	3	RFS-2, 7F		11	RFS-2, 8F	
Brown	4	RFS-2, 7M		12	RFS-2, 8M	
Gray	5	RFS-1, 3F		13	RFS-1, 4F	
Brown	6	RFS-1, 3M		14	RFS-1, 4M	
Gray	7	RFS-1, 7F		15	RFS-1, 8F	
Brown	8	RFS-1, 7M		16	RFS-1, 8M	

UPx3

Table 5-20 UPx3 Cables to RF Switch

Color	UPx3 Output	RFS Ports	✓
Gray	1	RFS-2, P2F	
Brown	2	RFS-2, P2M	
Gray	3	RFS-2, P1F	
Brown	4	RFS-2, P1M	
Gray	5	RFS-1, P2F	
Brown	6	RFS-1, P2M	
Gray	7	RFS-1, P1F	
Brown	8	RFS-1, P1M	

Cabling the Output Cables (CABLE PLANT to HUB)

The following section describes cabling the RF switch for output.



Note

The output cables (CABLE PLANT) on the RF Switch are cabled in the reverse order of the input cables (CMTS).

Equipment

- 16 cable bundles (MCX connector to F-connector—multicolor)
- 16 header blocks (installed)



Note

Two more cable bundles may be required if you intend to route the upstream cables and the downstream cables to different locations.

To cable the output to the cable plant, complete the following steps.

- Step 1** Install the output cables in the header blocks. Start with the header block on the far right (1H—1A). For easier troubleshooting, use the same color sequence that was used for CMTS cabling. A—red, B—white, C—blue, D—green. H—yellow, I—violet, J—orange, K—black.
- Step 2** Run the output cables (H—A) from header blocks to splitters, US laser receivers, or the low side of the diplex filters
- Step 3** Run the output cables (M—F) to the splitters and combiners, DS laser transmitters, or the high side of the diplex filters.

Figure 5-17 RF Switch Cable Plant Outputs (Turquoise)

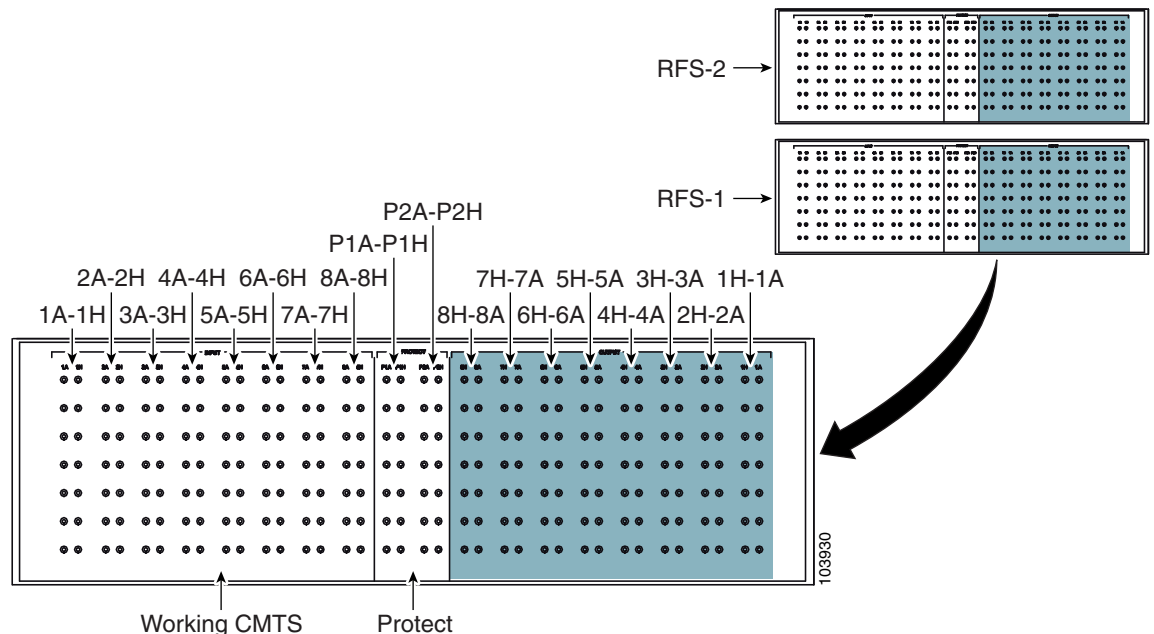

Powering On the RF Switch

To power on the RF switch, complete the following steps.

-
- Step 1** Check that the cables connecting the cable interface line cards in the Cisco uBR7246VXR to the Cisco uBR 3x10 RF Switch are in place.
- Step 2** Verify that the power cables are properly connected and secured.
- a. The AC-input power cable is connected and secured with the cable-retention clip.
 - b. The AC power cord is connected to the AC power source.
- or
- a. The DC-input leads (+48 and –48 DC) are connected and secured in the strain-relief on the power supply faceplate.
 - b. The DC ground wire is securely connected to the ground location (rack).
 - c. The DC leads are connected to the DC power source.
- Step 3** Place the power switch on the power supply in either the AC or DC position, depending on which type of power source is connected to your Cisco RF Switch. The green LED on the power supply goes on.
- Step 4** During the boot process, monitor the Cisco uBR 3x10 RF Switch system initialization and LED behavior for any errors or failures.
-



CHAPTER 6

Troubleshooting

This chapter contains troubleshooting information for the Cisco uBR 3x10 RF Switch.

Troubleshooting the Installation and Setup

[Figure 6-1 on page 6-2](#) shows the general troubleshooting strategy described in this chapter to troubleshoot possible scenarios under which the system may not perform because of the Cisco uBR 3x10 RF Switch hardware being inappropriately installed or set up. Refer to this chart, as necessary, to follow the steps to isolate hardware problems to a specific module; then resolve the problem, if possible.

If you are unable to easily solve the problem, see the [“Obtaining Technical Assistance” section on page 12](#) for information on contacting Cisco technical assistance.

To efficiently address your specific situation, use the checklist ([Table 6-1](#)) to log information that you will need to provide to the Cisco technical assistance representative.

Table 6-1 Information Checklist

Description	Information
Date you received your Cisco uBR 3x10 RF Switch	
Chassis serial number	
Type of software and release number	
Maintenance agreement or warranty information	
Brief description of the problem you are having	
Brief explanation of the steps you have taken to isolate and resolve the problem	

Figure 6-1 Troubleshooting Flowchart

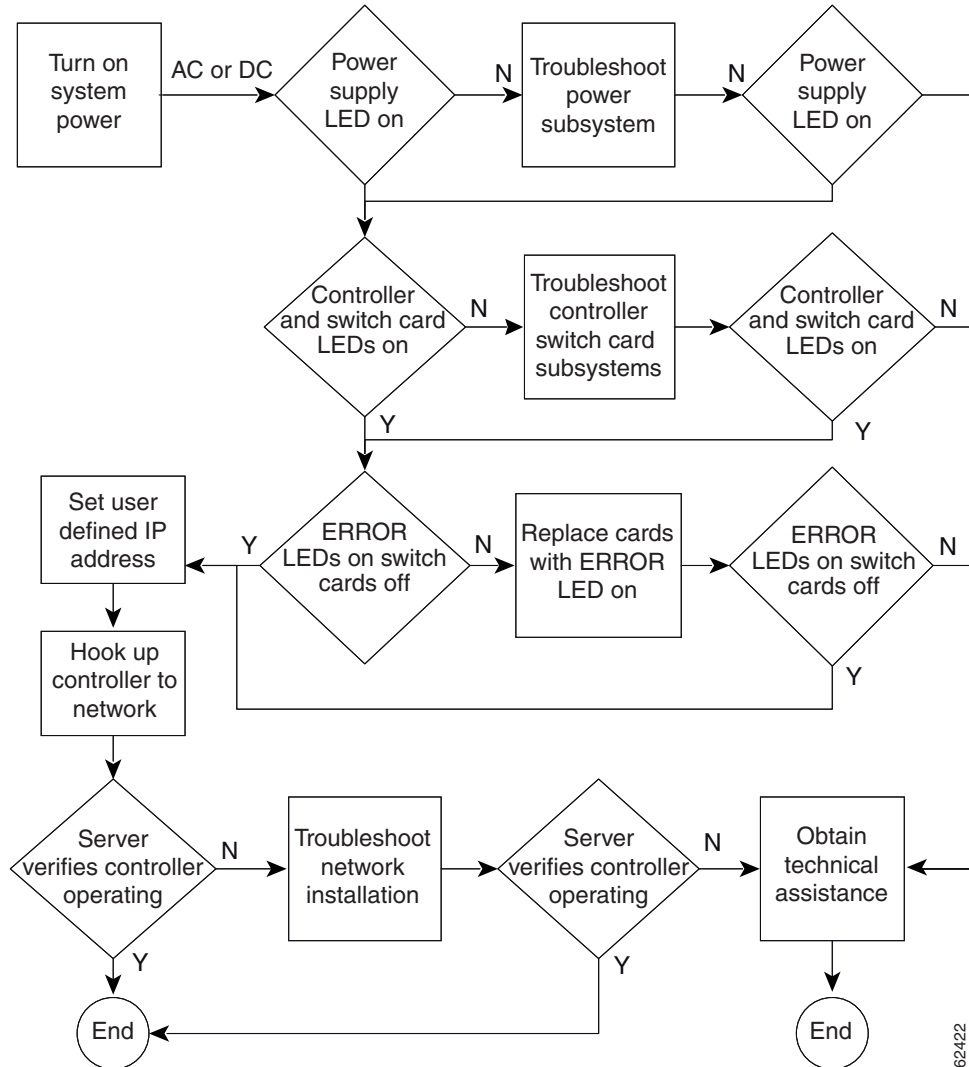

Troubleshooting the Power Subsystem

Check the following to help isolate a problem with the power system.

- Does the POWER LED come on when system power is turned on? If not:
 - AC—check to ensure that the AC power cord is plugged in to the power supply and the power source (wall or power strip).
 - DC—verify that the –48 and +48-V leads are correctly attached to the power supply.
 - Verify that the system is properly grounded.
 - Ensure that the voltage selection switch is in the appropriate AC or DC position.
- If you are unable to resolve the problem, see the [“Obtaining Technical Assistance”](#) section on page 12 for information on contacting Cisco technical assistance.

Troubleshooting the Ethernet Controller

Rfswitch App

The RfswitchApp (residing in flash memory) is the main system firmware component. It provides full network functionality (Telnet, TFTP, SNMP Agent) and line card control. The SysLoader (residing in boot flash memory) is a special build of the RfswitchApp firmware without SNMP agent support or line card control functionality to help increase reliability, because it is normally invoked as a result of a system crash. The SysLoader is capable of sending SNMPv1 traps as simple UDP packets, and fully supports Telnet and TFTP operations.

The Ethernet controller firmware is structured into three parts, the ROMMON, the SysLoader, and the main RfswitchApp. The SysLoader component is stored in onboard flash memory designated as the bootflash memory. The RfswitchApp resides in a separate area designated as flash memory.

The ROMMON is the first component to run. It is invoked whenever a reset event occurs, either by bootup, system crash, or software reload. The ROMMON is responsible for determining the cause of the reset event and controls the next phase of system bootup.

If the reset event is because of a system crash, the ROMMON attempts to load the SysLoader from bootflash memory into RAM and run it. If the bootflash memory is invalid, the ROMMON will then attempt to load the RfswitchApp from flash as a last resort. If the cause of the reset event was a normal bootup or reload, then an attempt is made to load and run the RfswitchApp. If this fails, then an attempt is made to load and run the SysLoader.

**Note**

The system prompt changes from rfswitch> to Sys> if the SysLoader is running. If the ROMMON is unable to load either the SysLoader or RfswitchApp, then it remains in control, and the controller's SYS LED is off and the ERR LED flashes.

Ethernet Controller LEDs

If the Ethernet controller LEDs do not come on as expected, check the following items:

- SYS LED is on, ERR LED is off
 - System has successfully booted
- All LEDs remain off
 - Troubleshoot the power subsystem
- SYS LED is off, ERR LED is on
 - The system has detected a bootup error or system crash event. Use the **show log** command to view the system event log to determine the cause of the problem.
- SYS LED is on, ERR LED is on
 - A problem has been detected configuring or controlling the switch modules. One or more of the switch modules ERROR LEDs is on. If so, refer to the [“Troubleshooting Upstream and Downstream Switch Modules”](#) section on page 6-6.

Ethernet Controller Switch Settings

These switches are found on the Ethernet controller module PC board.

Figure 6-2 Ethernet Controller Faceplate and PC Board

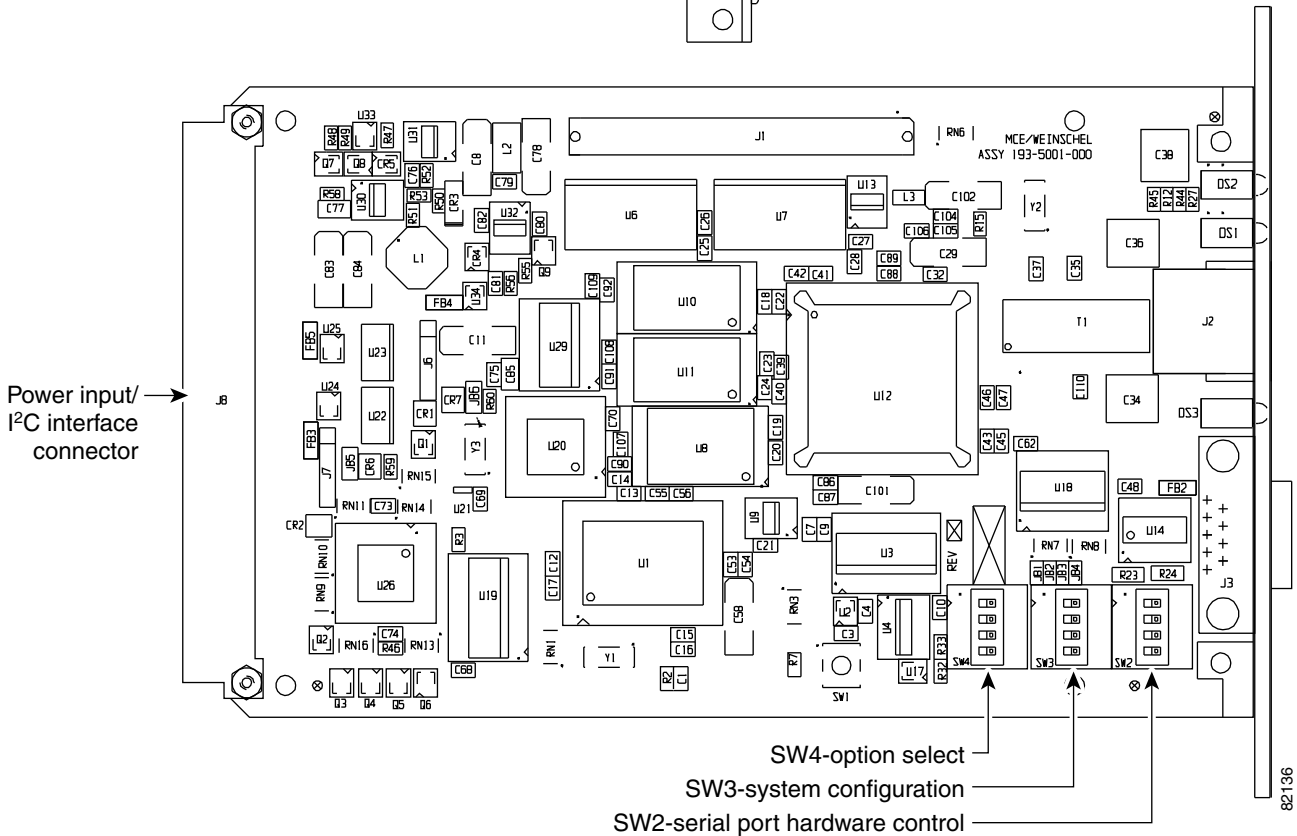
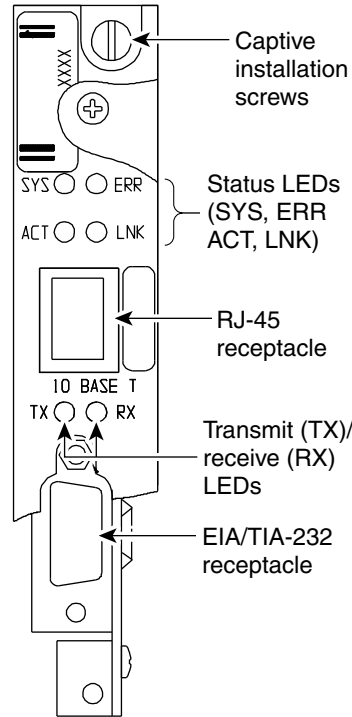

Table 6-2, Table 6-3, and Table 6-4 show hardware configuration switch settings for the Ethernet controller. These are set at the factory and should not be changed.

Table 6-2 SW4—Option Select

Switch	Name	Description	Default	Baud Rate Select		
				BR1	BR0	Rate
1	--	Not used	OFF	0	0	9600
2	--	Not used	OFF	1	0	19200
3	BR1	Baud rate select	OFF	0	1	38400
4	BR0	Baud rate select	OFF	1	1	57600

Table 6-3 SW3— System Configuration

Switch	Name	Description	Default	Memory Select			Load Sequence Override		
				MR1	MR2	Description	LS1	LS2	Description
1	MS1	Memory select	OFF	0	0	Normal	0	0	Normal sequence
2	MS2	Memory select	OFF	1	0	External ROM card	1	0	Run ROMMON with WDOG disabled
3	LS2	Load sequence override	OFF	0	1	Emulation mode (reserved)	0	1	Run SysLoader
4	LS1	Load sequence override	OFF	1	1	Emulation mode (reserved)	1	1	Normal sequence with WDOG disabled

Table 6-4 SW2—Serial Port Hardware Control

Switch	Name	Description	Default
1	CTST	EIA/TIA-422 Mode CTS Termination OFF—No termination ON—120-ohm termination	OFF
2	RXDT	EIA/TIA-422 Mode RXD Termination OFF—No termination ON—12-ohm termination	OFF
3	RTSS	EIA/TIA-422 Mode RTS line OFF—RTS+ not connected ON—RTS+ connected	OFF
4	MODE	Serial Port Mode OFF—EIA/TIA-232 ON—EIA/TIA-422	OFF

Troubleshooting Upstream and Downstream Switch Modules

Each upstream and downstream switch module has four LEDs that indicate the working status of the port. The upstream switch module operates over the frequency range of 5 to 70 MHz. The downstream (high-frequency) switch module operates over the frequency range of 54 to 860 MHz. During normal system operation, upstream switches all direct traffic to their respective default termination interfaces.

Each switch module takes on eight signal inputs from the power splitter and routes the signal to a protect output, or splits the inputs into two groups of four inputs and sets up the switch to select one of four inputs as a protect output. The relays are electromechanical and controlled through the power interface connector.

The switch card should provide a minimum of 60 dB of isolation from connector port to connector port during normal operation and more than 20 dB when operating in protect mode.

Status LEDs

Each upstream and downstream switch module has four LEDs on the faceplate that indicate the working status of the port as described in [Table 6-5](#).

Table 6-5 *Switch Board LED Descriptions*

LED Name	Color	Description
Protect 1	Green/Yellow	Indicates CMTS/PROTECT 1
Protect 2	Green/ Yellow	Indicates CABLE PLANT/PROTECT 2
Error 1	Off/Yellow	Indicates a channel problem in 1
Error 2	Off/Yellow	Indicates a channel problem in 2

When an upstream or downstream switch module initially boots, the LEDs briefly cycle on in sequence. After the bootup,

- The PROTECT1/PROTECT2 LEDs are on/off for single protect mode, or on/on for dual protect mode. The LED color reflects the current setting of the module protect mode switch—green for idle or yellow for any protect position.
- The ERROR1/ERROR2 LEDs stay on until the Ethernet controller detects and enumerates the switch module.
- If either of these LEDs remain on (yellow) after the system boot sequence, there is either a communications failure or a switch position failure. Use the **test module** command to diagnose failure.

If you are unable to resolve the problem, refer to the [“Obtaining Technical Assistance”](#) section on [page 12](#) for information on contacting Cisco technical assistance.

Cisco uBR 3x10 RF Switch Slot Information

Table 6-6 lists the RF modules and the ports assigned to each module.



The modules are listed as seen from the front of the RF switch.

8 **Table 6-6** Switching Matrix for the Cisco uBR 3x10 RF Switch (Upstream and Downstream Modules)

RFS Module	Working Ports	PROTECT Ports	Type	RFS Module	Working Ports	PROTECT Ports	Type
2	1H—8H	P1H, P2H ¹	upstream	1	1A—8A	P1A, P2A	upstream
4	1I—8I	P1I, P2I	upstream	3	1B—8B	P1B, P2B	upstream
6	1J—8J	P1J, P2J	upstream	5	1C—8C	P1C, P2C	upstream
8	1K—8K	P1K, P2K	upstream	7	1D—8D	P1D, P2D	upstream
10	1L—8L	P1L, P2L	upstream	9	1E—8E	P1E, P2E	upstream
12	1M—8M	P1M, P2M	downstream	11	1F—8F	P1F, P2F	downstream
14	not used	—	—	13	1G—8G	P1G, P2G	downstream

1. P2 is used only when the switch is in 4 + 1 mode.

Figure 6-3 RF Switch from Front

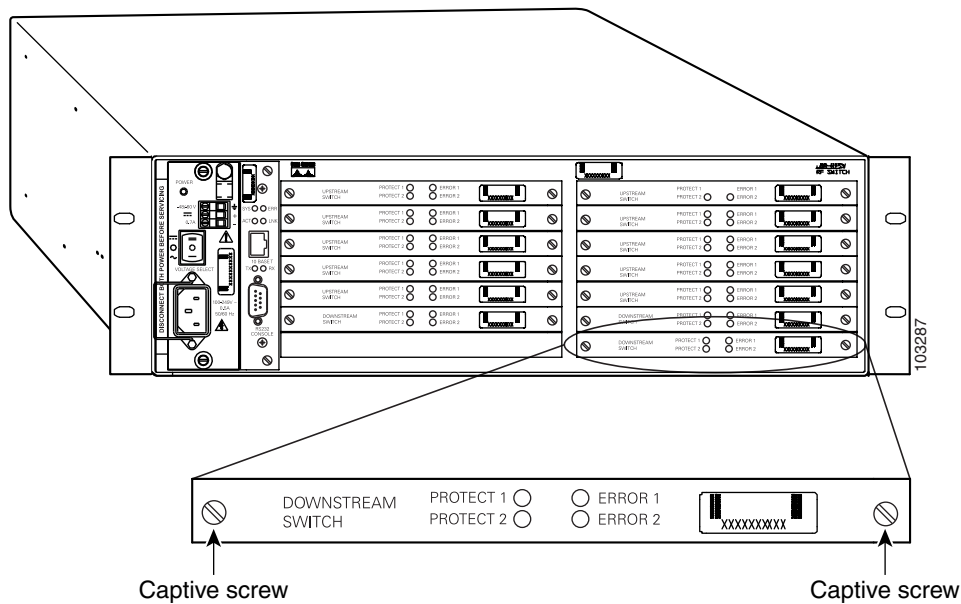



APPENDIX **A**

Specifications and Component Part Numbers

This appendix provides information on physical and RF specifications for the Cisco uBR 3x10 RF Switch.

Physical Specifications

The following table lists the physical specifications and power requirements for the Cisco uBR 3x10 RF Switch.

Table A-1 *Physical Specifications*

Description	Specification
Dimensions (H x W x D)	19 x 15.5 x 5.25 in. (842 x 384 x 132 mm)
Weight	36 lb (16.6 kg)
AC-input voltage rating	100 to 240 VAC (Operating Range: 90 to 254 VAC)
AC-input current rating	0.5 A
AC-input cable	18 AWG three-wire cable, with a three-lead IEC-320 receptacle on the power supply end and a country-dependent plug on the power source end
AC frequency	50-60 Hz
DC-input voltage rating	-48 to -60 VDC (Operating Range: -40.5 to -72 VDC)
DC-input current rating	0.7A
DC-input cable	14 AWG (2.5 mm ²) minimum recommended
DC voltage supplied	+12V
Temperature	Operational temperature range:32 to 104°F (0 to +40°C) Operating temperature range:23 to 151°F (-5 to +55°C)
Software requirement	Cisco IOS Release 12.2(8)BC2 or later version of Cisco IOS Release 12.2BC
Regulatory compliance	Safety: CSA950/UL1950, EN60950, IEC 60950, ACAN TS001, AS/NZS3260 EMC Emissions: CFR 47 part 15:2000 Class B; EN55022:1998 Class B; EN300386:2000; AS/NZS 3548:1995 Class B; CISPR22:1997 Class B; VCCI-3/2000.04; ICES-003:1994; CNS13438:1997 Class B EMC Immunity: EN61000-3-2:1995; EN61000-3-3:1995; EN55024:1998; EN50082-1:1992; EN50082-1:1997

RF Specifications

The following table lists the RF specifications for the Cisco uBR 3x10 RF Switch.

Table A-2 RF Specifications

Description	Specification	
Input/output impedance	75 ohms	
Maximum RF input power	+15 dBm (63.75 dBmV)	
Switch type	Electromechanical, absorptive for working path on-absorptive on the protect path	
Switch settling time per switch board	20 ms. maximum	
Downstream frequency range	54 to 860 MHz	
Typical downstream insertion loss	CMTS to Cable Plant	Protect to Cable Plant
<450 MHz:	5.25 dB	6.25 dB
>/=450 MHz, <550MHz	5.50 dB	6.50 dB
>/=550 MHz, <650 MHz	5.75 dB	7.00 dB
>/=650 MHz, <860 MHz	6.00 dB	8.00 dB
Downstream insertion loss flatness	± 1.1 dB from CMTS to Cable Plant; ± 2.1 dB from Protect to Cable Plant	
Downstream output return loss	>15.0 dB at <450 MHz; >12.0 dB at >/= 450 MHz	
Downstream input return loss	>15.0 dB	
Downstream isolation	>60 dB channel to channel in working mode; >52 dB from CMTS to Protect when in protect mode	
Upstream frequency range	5 to 70 MHz	
Typical upstream insertion loss	4.1 dB from cable plant to CMTS; 5.2 dB from cable plant to Protect	
Upstream insertion loss flatness	± 0.4 dB from Cable Plant to CMTS; ± 0.6 dB from Cable Plant to Protect	
Upstream input return loss	>16 dB	
Upstream isolation	>60 dB channel to channel in working mode; >60dB from CMTS to Protect when in protect mode	
Protect mode	CMTS return loss: >10 dB; Cable Plant return loss: >10 dB	

Part Numbers

Table A-4 lists component part numbers. Use these part numbers for reference when you are ordering spares or tools.

RF Switch Components

Table A-3 RF Switch Component Part Numbers

Component	Cisco Order Number	Weinschel Order Number ¹	WhiteSands Engineering Order Number
Cisco uBR 3x10 RF Switch	UBR-RFSW-3X10=	—	—
Power supply	74-2624-02=	001-491	—
Ethernet controller	74-2620-01=	193-5001-000	—
Upstream switch module	74-2622-01=	193-5002-000	—
Downstream switch module	74-2623-01=	193-5003-000	—
Rack mount kit	74-2625-01=	193-5017	—
Mounting brackets	74-2620-01	—	—

1. Weinschel URL: www.weinschel.com

Tools and Equipment

Table A-4 Tools and Equipment Part Numbers

Tools	WhiteSands Engineering Order Number ¹
Universal cable holder (UCH)	133-8447-026
Header block (RF switch)	MCXHEADERBK
MCX removal tool	RTOOLWSE (Cisco p/n: 51-3308-01)
F-connectors	ASFP
MCX connector	MCXFP
MCX female to F female adapter	531-40137
Crimp tool for MCXFP	47-10120
Crimp tool for ASFP	ACT-270
Stripper for MCXFP, ASFP	CPT-7538-125

1. Whitesands Engineering URL: www.whitesandsengineering.com

Cable Part Numbers

Table A-5 Cable Part Numbers and Vendors

Description	Cisco	WhiteSands	Belden	Where Used
Cable kit for MC16x, MC28C	CAB-RFSW-3X10-10T	74-2765-02	—	RFS ¹ to MC16x, MC28C (MCX to F)
Cable—single cable	CAB-RFSW-3X10-T	—	—	RFS to UPx ² (MCX to F)
3 meter cable kit for the MC5X20—dual-shielded	CAB-RFSW520TPMF	—	—	MC5X20 to cable plant (MCX to F)
3 meter cable kit for the MC5X20—quad-shielded	CAB-RFSW520QTPMF	—	—	MC5X20 to cable plant (MCX to F)
1 meter cable kit for the MC5X20	CAB-RFSW520TIMM	CAB-RFSW520TIMM	—	RFS to MC5X20 (MCX to MCX)
Cable kit (MC5X20)	—	74-2983-01-POP	—	MC5x20 cable kit, populated
Cable kit (MC5X20)	—	74-2984-01-DNS	—	3 meter, dense connector MC5x20 cable kit, populated
10 meter cable	—	74-2961-01	—	RFS to cable plant
Cable—single	—	WS940	YR46940	no connectors
Cable—5 bundle	—	WS942	YR46942	no connectors
Cable—10 bundle	—	WS943	YR46943	no connectors

1. RFS—RF switch
2. UPx—upconverter



INDEX

A

- AC power
 - connecting to [3-16](#)

B

- bootflash memory [6-3](#)
- brackets [3-11](#)

C

- cable colors
 - DS ports (MC16x) [5-13](#)
 - US ports (MC16x) [5-9, 5-10](#)
 - US ports (MC28C) [5-17](#)
- cable headend
 - certification [2-7](#)
 - distance limitations [2-7](#)
 - interference [2-7](#)
 - wiring [2-7](#)
- cable management bracket
 - installing [3-8](#)
- cables [4-4](#)
 - bundles [4-5](#)
 - cable plant [5-25](#)
 - coaxial [2-10](#)
 - crossover [1-5, 2-11](#)
 - interference [2-7](#)
 - management bracket [2-10, 3-8](#)
 - number of [5-5](#)
 - part numbers [A-4](#)
 - protect cards [5-9, 5-10](#)

- RF switch [5-24](#)
- rollover [1-5, 2-11](#)
- safety guidelines [2-3](#)
- straight through [2-11](#)
- types [5-5](#)
- ungrounded and uninsulated [2-4](#)
- vendors [A-4](#)
- working line card [5-9, 5-10](#)

cabling

- cable plant [4-19, 4-29](#)
- Cisco uBR-MC16x cards [5-8](#)
- Cisco uBR-MC28C line card [5-16](#)
- DS ports [5-12, 5-19](#)
- DS ports (MC28C) [5-20, 5-23](#)
- line cards [4-15, 4-26](#)
- output ports [5-13](#)
- protect line card [5-11, 5-19](#)
- uBR10012 card slots [4-22](#)
- upconverter [5-12, 5-23](#)
- upconverter input [4-17](#)
- upconverter output [4-18](#)
- working line card [5-8, 5-16](#)

chassis

- features [1-1](#)
- lifting [2-2](#)

commands

- show environment [2-6](#)

- configuration example [3-4, 3-5](#)

connecting power

- AC power [3-16](#)
- DC power [3-17](#)

- connectors [4-6](#)

- console port settings [3-2](#)

D

- DC power
 - connecting to [3-17](#)
- distance limitations, transmission [2-7](#)
- downstream module [1-8](#)
- DS ports (MC28C) [5-21](#)

E

- electromagnetic pulse (EMP), avoiding [2-7](#)
- electrostatic discharge, preventing [2-4](#)
- EMI, shielding [2-4](#)
- ethernet controller [1-4](#)
 - switch location, setting [6-4](#)
- ethernet interface [1-2](#)

F

- F-connectors [5-5](#)
- frequency range [1-1, 1-7, 1-8, 1-9, 6-6](#)

G

- gravity, maintaining low center [2-8](#)
- grounding [3-14, 3-15](#)
 - tools [3-15](#)

H

- header block [5-5](#)
 - installation [5-7](#)
 - protect [5-11](#)
- header blocks [4-5, 4-8](#)
 - installing [4-9](#)

I

- installation
 - brackets [3-11](#)
 - checking the shipping container [2-11](#)
 - checklist [3-2](#)
 - connecting power [3-14](#)
 - general [3-13](#)
 - RF switch [3-12](#)
 - safety recommendations [2-2](#)
 - site requirements [2-5](#)
 - tools for [2-9, 3-3, 3-9](#)
- installing
 - cable management brackets [3-8](#)
 - chassis on a tabletop [3-13](#)
 - in the rack [3-7](#)
 - rack-mounting brackets [3-6](#)
- interface
 - slot numbers [1-3, 1-4](#)
- interference, radio frequency [2-7](#)

J

- jewelry, avoiding for safety [2-2](#)

L

- LEDs
 - DC OK [4-31](#)
 - downstream module [1-8](#)
 - ethernet controller [1-6, 6-3](#)
 - power supply [1-5, 5-26](#)
 - troubleshooting [6-6](#)
 - upstream module [1-7](#)
- lifting the chassis [2-2](#)
- lightning storm, safety during [2-3](#)

M

MAC address [1-3, 1-4](#)
 MAC domain [4-13](#)
 mapping
 Cisco uBR-MC28C line cards [5-16](#)
 working and protect cards [5-6](#)
 MCX connector removal tool [2-9](#)
 MCX connectors [5-5](#)
 midplane [1-9](#)

N

N+1 redundancy [1-1, 1-5, 1-10, 4-1, 4-3, 4-4, 4-6, 4-7, 4-11, 4-21, 5-4](#)
 note, description of [1-4](#)

O

online insertion and removal [1-4](#)
 overheating, preventing [2-6](#)

P

part numbers
 cables [A-4](#)
 mounting brackets [A-3](#)
 RF switch components [A-3](#)
 tools and equipment [A-3](#)
 power
 AC, site requirements [2-5](#)
 connections
 AC power [3-16](#)
 DC power [3-17](#)
 cord [2-2](#)
 DC
 site requirements [2-5](#)
 emergency power-off switch [2-3](#)
 surge suppression [2-7](#)

 ungrounded [2-3](#)
 voltage [1-4](#)
 power factor corrector, power supply [2-5](#)
 power on [5-26](#)
 procedures
 cabling input ports [5-20](#)
 cabling output cables [5-25](#)
 cabling output ports (upconverter) [5-23](#)
 checking the shipping container [2-11](#)
 connecting power [3-14](#)
 general installation [3-13](#)
 installing brackets [3-11](#)
 installing in a rack [3-12](#)

R

racking configurations [3-10](#)
 Cisco uBR-MC16x [5-2](#)
 Cisco uBR-MC28C [5-3](#)
 rackmounting
 chassis [3-3, 3-7, 3-9](#)
 rack-mounting brackets
 installing [3-6](#)
 location [1-3](#)
 part numbers [A-3](#)
 radio frequency interference (RFI) [2-7](#)
 redundancy configuration [5-1, 5-2, 5-3](#)
 RFI [2-7](#)
 RF switch [5-12, 5-17, 5-18, 5-19, 5-23, 5-24](#)
 power on [5-26](#)
 specifications [A-1](#)
 turn on power [4-31](#)
 rf switch
 component partnumbers [A-3](#)
 RFswitchApp [6-3](#)

S

- safety recommendations [2-2](#)
- show commands
 - show environment [2-6](#)
- site configuration [2-6](#)
- site requirements
 - AC power [2-5](#)
 - DC power [2-5](#)
 - environment [2-6](#)
 - equipment racks [2-8](#)
 - plant wiring [2-7](#)
- slot numbers [1-3, 1-4](#)
 - Cisco uBR10012 router [4-10](#)
 - protect card [4-11](#)
- SNMP [1-1, 1-2, 1-5](#)
- status
 - environmental [2-6](#)

T

- telephone jacks [2-4](#)
- tools [4-4](#)
 - for installation [2-9, 3-3, 3-9](#)
 - part numbers [A-3](#)
- troubleshooting
 - checklist [6-2](#)
 - ethernet controller [6-3](#)
 - flowchart [6-2](#)
 - power subsystem [6-2](#)
 - RF switch modules [6-6](#)
 - RF switch slot information [6-6](#)
- turning on the RF switch [5-26](#)

U

- universal cable holder [4-8](#)
- upconverter [4-4, 4-15, 5-21, 5-22, 5-24](#)
 - cabling [4-17, 4-18](#)

- in rack [4-2](#)
- Vecima URL [3-3, 3-9](#)
- upstream module [1-7](#)

V

- Vecima [2-10, 3-5, 4-2, 4-4](#)

W

- warning
 - DC power disconnection [3-17](#)
 - disconnect device warning [3-17](#)
 - jewelry removal [3-14](#)
 - TN power [3-16](#)
- WhiteSands Engineering [4-4](#)
- wiring
 - interference [2-7](#)
 - plant [2-7](#)
 - telephone [2-3](#)